

# Flotec®

Water Is Our Business®

**Pump Catalog**

**2011-2012**



**Sump**



**Sewage**



**Utility**



**Well**





## Water Is Our Business®

Flotec is a division of Pentair Water, a global leader in providing innovative products for the movement, treatment and enjoyment of water. Flotec is a widely respected brand of pumps you can trust for performance, quality and long life.

We make sump, lawn and garden, pool and spa, sewage and effluent pumps and home water systems... products you seldom think about, but really appreciate when you need them. Designed for quick and easy installation, all of our products come with industry-leading warranties. We've been making pumps for over 75 years, working to bring you great performance and a quality selection.

**Flotec's complete line helps you tackle any pumping project with confidence.**



[www.flotecwater.com](http://www.flotecwater.com)

1-800-365-6832

<b>SUMP PUMPS</b>	4-26
-------------------	------

<b>SEWAGE PUMPS</b>	27-35
---------------------	-------

<b>UTILITY PUMPS</b>	36-47
----------------------	-------

<b>POOL PUMPS</b>	48-49
-------------------	-------

<b>SPRINKLER PUMPS</b>	50-53
------------------------	-------

<b>WELL PUMPS</b>	54-71
-------------------	-------

Shallow Well	56-63
Convertible Well	64-69
Submersible Well	70-71
Tanks	72-77
Accessories	78-81
Warranty & Glossary	82-83





# Sump Pumps

For best defense against flooding, a sump pump removes drainage water that collects in the sump basin located in your basement or crawl space. Replacing a sump pump typically can take about 30 minutes to 1 hour and can be done with common household tools.

## Product Line Overview

- Submersible and pedestal pumps
- Vertical, tethered and electronic switches
- 1/4 HP to 1 HP ranges, up to 5,460 GPH
- Battery-powered backup sump pump systems
- Complete sink pump system available
- 1-year to 5-year warranties

## Flotec® PROFESSIONAL

We've taken the best of what contractors have asked for and developed an elite group of products that meet and exceed the requirements of any professional installer. Flotec® Professional pumps are exactly what professional contractors demand!

### PARTS<sub>2</sub>O™ Accessories

Universal Hose Kit	FP0012-6U
Check Valves	FP0026-6D FP0026-10
Float Switches:	
Tethered	FP18-15BD
Vertical	FPS17-66
Direct-Connect	FPFS
Pedestal	FP0018-7D
18" Sump Basin	FPW73-19
18" Sump Basin Lid	FPW73-20



# Cast Iron Sump Pump

**High-Output Professional-Grade  
Sump Pump with Electronic Switch**



PROFESSIONAL

**RUGGED CONSTRUCTION**

**ENERGY-EFFICIENT PSC MOTOR**

**INNOVATIVE ELECTRONIC  
SWITCH TECHNOLOGY**

**5-YEAR WARRANTY**



**Innovative Z-Cross  
Switch Technology**

Prevents voltage and current spikes, the primary cause of switch failure.

**Maintenance Free**

Neither residue nor water temperature will affect switch operation.

**High-Water Alarm**

Loud external alarm alerts you of high-water situations. Includes easy connection to home security or voice dialer system (sold separately).

**91 GPM** 5,460 GPH

**MODEL  
E10OELT**

**1 HP**

Discharge height above pumping level	0'	5'	10'	15'	20'	25'	Max. Lift	Float Switch		Solids Handling	Carton Dimensions	Pallet Quantity	Weight
	91 5460	80 4800	72 4320	62 3720	48 2880	26 1560		On 8.75"	Off 4.25"				
<b>Gallons/min. E10OELT</b> <b>Gallons/hr. 022315342163</b>													

**PERFORMANCE CURVE**

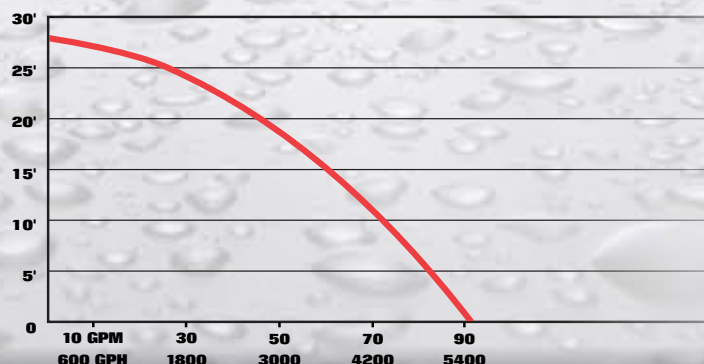

**115VAC 1 Phase**

**10' Power Cord**

**1.5" FNPT Discharge**

Includes:

1-1/2" discharge (meets standard code approvals),  
10' power cord for easy installation,  
detailed owner's manual

Check valve replacement recommended

# Cast Iron Sump Pumps

High-Output Professional-Grade  
Sump Pumps with Vertical Switch



**VERTICAL  
FLOAT SWITCH**

**RUGGED  
CONSTRUCTION**

**ENERGY-EFFICIENT  
PSC MOTOR**

**5-YEAR WARRANTY**



**88 GPM** 5,280 GPH  
**80 GPM** 4,800 GPH

**MODEL E75VLT**

**3/4 HP**

**MODEL E50VLT**

**1/2 HP**

Discharge height above pumping level	E75VLT 022315345799		E50VLT 022315342782		Max. Lift	Float Switch		Solids Handling	Carton Dimensions	Pallet Quantity	Weight
	Gallons/min.	Gallons/hr.	Gallons/min.	Gallons/hr.		On	Off				
0'	88	5280	80	4800	25'	7.5"	3"	3/8"	12.13" x 10.13" x 15.38"	36	25 lbs.
5'	67	4020	72	4320	22'	7.5"	3"	3/8"	12.13" x 10.13" x 15.38"	48	23 lbs.
10'	53	3180	61	3660							
15'	30	1800	44	2640							
20'	17	1020	17	1020							

## PERFORMANCE CURVES

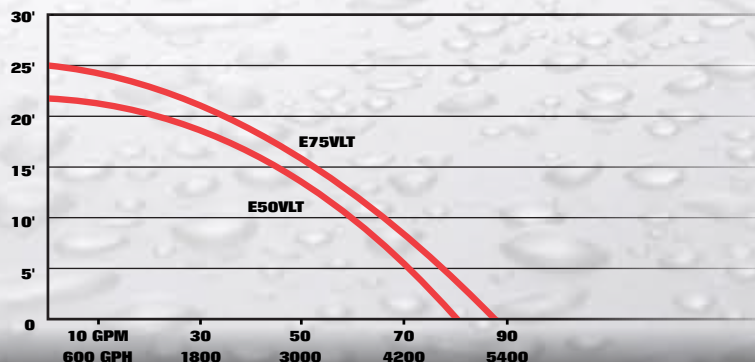

**115VAC 1 Phase**

**10' Power Cord**

**1.5" FNPT Discharge**

Includes:

1-1/2" discharge (meets standard code approvals),  
10' power cord for easy installation,  
detailed owner's manual

Check valve replacement recommended

# Cast Iron Sump Pump

High-Output Professional-Grade  
Sump Pump with Tethered Switch



**TETHERED  
FLOAT SWITCH**

**RUGGED  
CONSTRUCTION**

**ENERGY-EFFICIENT  
PSC MOTOR**

**5-YEAR WARRANTY**



**80 GPM** 4,800 GPH

**MODEL  
E50TLT**

**1 / 2 HP**

Discharge height above pumping level	0'	5'	10'	15'	20'	Max. Lift	Float Switch		Solids Handling	Carton Dimensions	Pallet Quantity	Weight
	<b>Gallons/min. E50TLT</b> <b>Gallons/hr. 022315342149</b>	80 4800	72 4320	61 3660	44 2640	17 1020	22'	On 13.5"	Off 4.5"	3/8"	12.13" x 10.13" x 15.38"	36

## PERFORMANCE CURVE

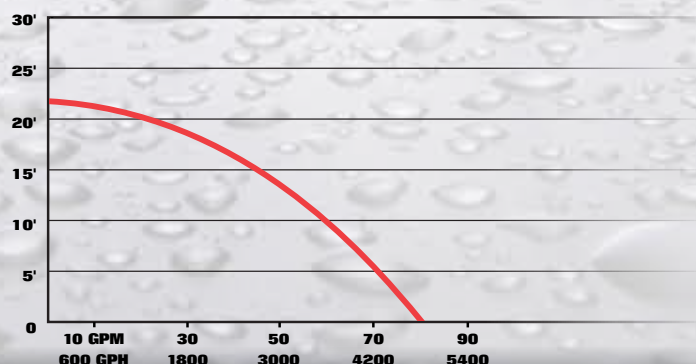

**115V AC 1 Phase**

**10' Power Cord**

**1.5" FNPT Discharge**

Includes:

1-1/2" discharge (meets standard code approvals),  
10' power cord for easy installation,  
detailed owner's manual

Check valve replacement recommended

# Cast Iron/Stainless Steel Sump Pump



## High-Output Sump Pump with Electronic Switch

### Powerful Performance

High-efficiency PSC technology saves operating costs

### Rugged Construction

Cast iron and stainless steel corrosion-resistant design

### Virtually Silent Operation

Lets you sleep all night

### Electronic Float Switch

Operates in small 10" basins and larger



### Innovative Z-Cross Switch Technology

Prevents voltage and current spikes, the primary cause of switch failure.

### Maintenance Free

Neither residue nor water temperature will affect switch operation.

### High-Water Alarm

Loud external alarm alerts you of high-water situations. Includes easy connection to home security or voice dialer system (sold separately).

**3/4 HP 5150 GPH**  
FPSC5000A

PERFORMANCE (GPH)							FLOAT SWITCH		SOLIDS HANDLING
DISCHARGE HEIGHT ABOVE PUMPING LEVEL	0'	5'	10'	15'	20'	MAX. LIFT	ON	OFF	
FPSC5000A	5150	4700	4100	3500	2820	32'	6.5"	3"	3/8"

MODEL	WARRANTY	UPC	CARTON DIMENSIONS	PALLET QTY.	WEIGHT
FPSC5000A	5 YEAR	022315357747	12.375" x 10.375" x 15.5"	48	24 LBS.

Includes:

1-1/2" NPT discharge, grounded 10' power cord, piggyback-style switch for automatic or manual operation, detailed owner's manual

Check valve replacement recommended





# Cast Iron/Stainless Steel **Sump Pumps**



**High-Output Sump Pumps with Vertical Switch**

**Powerful Performance**

High-efficiency PSC technology saves operating costs

**Rugged Construction**

Cast iron and stainless steel corrosion-resistant design

**Virtually Silent Operation**

Lets you sleep all night

**Vertical Float Switch**

Operates in small 10" basins and larger



<b>3/4 HP</b> 5150 GPH FPSC4550A	<b>1/2 HP</b> 4680 GPH FPSC3250A	<b>1/3 HP</b> 4380 GPH FPSC2250A
-------------------------------------	-------------------------------------	-------------------------------------

PERFORMANCE														
MODEL/UPC	HP	GPH	WARR. YEARS	GALLONS PER MINUTE PUMPED AT DIFFERENT DEPTHS TO WATER IN FEET						FLOAT SWITCH		SOLIDS HANDLING	CARTON DIMS. (IN INCHES)	WEIGHT (LBS.)
				0'	5'	10'	15'	20'	MAX. LIFT	ON	OFF			
<b>FPSC4550A</b> 022315166509	<b>3/4</b>	<b>5150</b>	5	5150	4700	4100	3500	2820	32'	6.5"	3"	3/8"	12.2 x 10.8 x 15.4 36/PALLET	21.6
<b>FPSC3250A</b> 022315138223	<b>1/2</b>	<b>4680</b>	5	4680	4380	3840	3300	2340	28'	6.5"	3"	3/8"	12.375 x 10.375 x 15.5 48/PALLET	22
<b>FPSC2250A</b> 022315138216	<b>1/3</b>	<b>4380</b>	3	4380	4020	3540	3000	1800	26'	6.5"	3"	3/8"	12.375 x 10.375 x 15.5 48/PALLET	22.1

Includes:

1-1/2" NPT discharge, grounded 10' power cord, piggyback-style switch for automatic or manual operation, detailed owner's manual

Check valve replacement recommended

Cast Iron/Stainless Steel

*WaterCannon*  
series™

# Sump Pumps

**High-Output Sump Pumps with Tethered Switch**

**Powerful Performance**

High-efficiency PSC technology saves operating costs

**Rugged Construction**

Cast iron and stainless steel corrosion-resistant design

**Virtually Silent Operation**

Lets you sleep all night

**Tethered Float Switch**

Operates in 14" basins and larger



**1/2 HP 4680 GPH**  
FPSC3200A

**1/3 HP 4380 GPH**  
FPSC2200A

PERFORMANCE (GPH)							FLOAT SWITCH		SOLIDS HANDLING
DISCHARGE HEIGHT ABOVE PUMPING LEVEL	0'	5'	10'	15'	20'	MAX. LIFT	ON	OFF	
FPSC3200A	4680	4380	3840	3300	2340	28'	15"	7"	3/8"
FPSC2200A	4380	4020	3540	3000	1800	26'	15"	7"	3/8"

MODEL	WARRANTY	UPC	CARTON DIMENSIONS	PALLET QTY.	WEIGHT
FPSC3200A	5 YEAR	022315101333	12.2" x 10.8" x 15.6"	36	22.1 LBS.
FPSC2200A	3 YEAR	022315101319	12.2" x 10.8" x 15.4"	36	21.3 LBS.

Includes:

1-1/2" NPT discharge, grounded 10' power cord, piggyback-style switch for automatic or manual operation, detailed owner's manual

Check valve replacement recommended



# Cast Iron Sump Pump

**Sump Pump  
with Vertical Switch**

**Rugged Cast Iron Construction**

Designed for years of trouble-free operation

**Recessed Vortex Impeller**

Resists clogging

**Heavy-Duty Integrated  
Vertical Switch**

**Great for Laundry Applications**

Passes up to 1/2" solids. 1-1/2" NPT discharge



## Contractor-Preferred Switch

**1/3 HP 3360 GPH  
FPSC3350A**

PERFORMANCE (GPH)							FLOAT SWITCH		SOLIDS HANDLING
DISCHARGE HEIGHT ABOVE PUMPING LEVEL	0'	5'	10'	15'	20'	MAX. LIFT	ON	OFF	
<b>FPSC3350A</b>	3360	2880	2400	1740	900	24'	9"	4"	1/2"

MODEL	WARRANTY	UPC	CARTON DIMENSIONS	PALLET QTY.	WEIGHT
<b>FPSC3350A</b>	3 YEAR	022315358133	12.5" x 9.75" x 13"	42	24 LBS.

Includes:

1-1/2" NPT discharge, grounded 10' power cord, piggyback-style switch for automatic or manual operation, detailed owner's manual

Check valve replacement recommended



# Cast Iron Sump Pumps

With Tethered Switch

## Rugged Cast Iron Construction

For heavy-duty applications

## Tethered Float Switch

Operates in 14" basins and larger

## Energy-Efficient Motor

With thermal overload protection



**1/2 HP** 4200 GPH  
FPSC3000A

**1/3 HP** 3300 GPH  
FPSC2000A

PERFORMANCE (GPH)							FLOAT SWITCH		SOLIDS HANDLING
DISCHARGE HEIGHT ABOVE PUMPING LEVEL	0'	5'	10'	15'	20'	MAX. LIFT	ON	OFF	
FPSC3000A	4200	3690	3000	2100	1140	26'	14.5"	6.5"	3/8"
FPSC2000A	3300	3120	2280	1380	480	22'	14.5"	6.5"	3/8"

MODEL	WARRANTY	UPC	CARTON DIMENSIONS	PALLET QTY.	WEIGHT
FPSC3000A	1 YEAR	022315357013	12" x 13.04" x 8.13"	90	24 LBS.
FPSC2000A	1 YEAR	022315357020	12" x 13.04" x 8.13"	90	24 LBS.

Includes:

1-1/2" NPT discharge, grounded 8' power cord, piggyback-style switch for automatic or manual operation, detailed owner's manual

Check valve replacement recommended

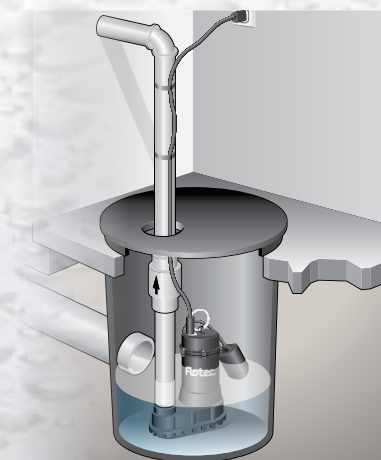

# Cast Iron/Thermoplastic Sump Pumps

**With Vertical Switch**

## Rugged Cast Iron Construction

Maximizes pump life

## Automatic Vertical Float Switch

Designed for minimum 10" diameter sump basin

## Heavy-Duty Motor

With overload protection

## Easy Installation

Includes 8' power cord



**1/2 HP** 3630 GPH  
FPSC3150A

**1/3 HP** 3150 GPH  
FPSC2150A

PERFORMANCE (GPH)							FLOAT SWITCH		SOLIDS HANDLING
DISCHARGE HEIGHT ABOVE PUMPING LEVEL	0'	5'	10'	15'	20'	MAX. LIFT	ON	OFF	
FPSC3150A	3630	3200	2700	2000	1200	24'	7.5"	3"	3/8"
FPSC2150A	3150	2760	2160	1410	-	20'	7.5"	3"	3/8"

MODEL	WARRANTY	UPC	CARTON DIMENSIONS	PALLET QTY.	WEIGHT
FPSC3150A	3 YEAR	022315357730	9.65" x 9.5" x 13.125"	75	16.3 LBS.
FPSC2150A	2 YEAR	022315357723	9.65" x 9.5" x 13.125"	75	11.2 LBS.

Includes:

1-1/2" NPT discharge, grounded 8' power cord, piggyback-style switch for automatic or manual operation, detailed owner's manual

Check valve replacement recommended



## Thermoplastic Sump/Utility Pump

### High-Output Performance

#### Superior Pumping Capacity

Pumps up to 7000 gallons per hour

#### Powerful 3/4 HP Performance

High-efficiency PSC technology saves operating costs

#### Corrosion-Resistant Construction

Designed for years of trouble-free operation

#### Tethered Float Switch

Operates in 14" basins and larger

#### Built-in Check Valve



**3/4 HP 7000 GPH**  
FP0S6000A

PERFORMANCE (GPH)							FLOAT SWITCH		SOLIDS HANDLING
DISCHARGE HEIGHT ABOVE PUMPING LEVEL	0'	5'	10'	15'	20'	MAX. LIFT	ON	OFF	
FP0S6000A	7000	6000	5040	3840	2340	25'	13.7"	4.7"	1/8"

MODEL	WARRANTY	UPC	CARTON DIMENSIONS	PALLET QTY.	WEIGHT
FP0S6000A	3 YEAR	022315162846	9.625" x 7.25" x 14.25"	72	12.1 LBS.

#### Includes:

Adapter for 1-1/4" or 1-1/2" discharge pipe, grounded 8' power cord, piggyback-style switch for automatic or manual operation, built-in check valve, detailed owner's manual



# Pre-Plumbed Easy Sump™

**Thermoplastic with  
Vertical Switch**

**Versatile Discharge Options**

Hard plumb or use flexible hose kit (included) to redirect water from sump basin

**Corrosion-Resistant Construction**

Designed for years of trouble-free operation

**Vertical Float Switch**

Operates in 10" basins and larger



**Measure & Cut**



**Drop In Easy Sump™**



**Connect & Tighten**

**INSTALLATION MADE EASY**

Hardware pre-assembled

**SAVES TIME**

Installs in minutes

**SAVES MONEY**

No need to call a plumber



**1/2 HP 3630 GPH**  
**FPRP3250C**

PERFORMANCE (GPH)							FLOAT SWITCH		SOLIDS HANDLING
DISCHARGE HEIGHT ABOVE PUMPING LEVEL	0'	5'	10'	15'	20'	MAX. LIFT	ON	OFF	
<b>FPRP3250C</b>	3630	3200	2700	2000	1200	24'	8"	3.5"	3/8"

MODEL	WARRANTY	UPC	CARTON DIMENSIONS	PALLET QTY.	WEIGHT
<b>FPRP3250C</b>	1 YEAR	022315357679	10.01" x 12.88" x 33.87"	36	15 LBS.

Includes:

Detailed owner's manual, universal check valve, pre-plumbed 24" long 1-1/4" PVC pipe, pre-assembled vertical switch, high-performance submersible 1/2 HP sump pump, 24' flexible hose kit

# Thermoplastic Sump Pumps

With Vertical Switch

## Corrosion-Resistant Construction

Designed for years of trouble-free operation

## Vertical Float Switch

Operates in 10" basins and larger

## Easy Installation

1-1/4" or 1-1/2" discharge



**1/2 HP** 3630 GPH  
FP0S3250A

**1/3 HP** 3150 GPH  
FP0S2450A

PERFORMANCE (GPH)							FLOAT SWITCH		SOLIDS HANDLING
DISCHARGE HEIGHT ABOVE PUMPING LEVEL	0'	5'	10'	15'	20'	MAX. LIFT	ON	OFF	
FP0S3250A	3630	3200	2700	2000	1200	24'	8"	3.5"	3/8"
FP0S2450A	3150	2760	2160	1410	-	20'	8"	3.5"	3/8"

MODEL	WARRANTY	UPC	CARTON DIMENSIONS	PALLET QTY.	WEIGHT
FP0S3250A	3 YEAR	022315138209	7.94" x 12.57" x 7.91"	90	10.2 LBS.
FP0S2450A	2 YEAR	022315138193	7.94" x 12.57" x 7.91"	90	10.15 LBS.

Includes:

1-1/4" or 1-1/2" discharge, grounded 8' power cord, piggyback-style switch for automatic or manual operation, detailed owner's manual

Check valve replacement recommended

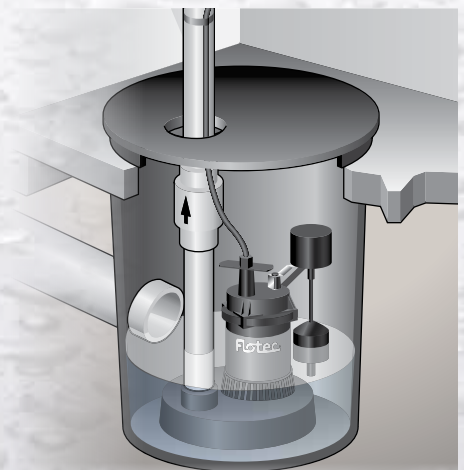



# Thermoplastic Sump Pumps

**With Tethered Switch**

### Corrosion-Resistant Construction

Designed for years of trouble-free operation

### Tethered Float Switch

Operates in 14" basins and larger

### Easy Installation

1-1/4" or 1-1/2" discharge



**1/2 HP** 3630 GPH  
FP0S3200A

**1/3 HP** 3150 GPH  
FP0S2400A

PERFORMANCE (GPH)							FLOAT SWITCH		SOLIDS HANDLING
DISCHARGE HEIGHT ABOVE PUMPING LEVEL	0'	5'	10'	15'	20'	MAX. LIFT	ON	OFF	
FP0S3200A	3630	3200	2700	2000	1200	24'	14"	6"	3/8"
FP0S2400A	3150	2760	2160	1410	-	20'	14"	6"	3/8"

MODEL	WARRANTY	UPC	CARTON DIMENSIONS	PALLET QTY.	WEIGHT
FP0S3200A	3 YEAR	022315101326	7.94" x 12.57" x 7.91"	90	10.2 LBS.
FP0S2400A	2 YEAR	022315100046	7.94" x 12.57" x 7.91"	90	9.95 LBS.

Includes:

1-1/4" or 1-1/2" discharge, grounded 8' power cord, piggyback-style switch for automatic or manual operation, detailed owner's manual

Check valve replacement recommended

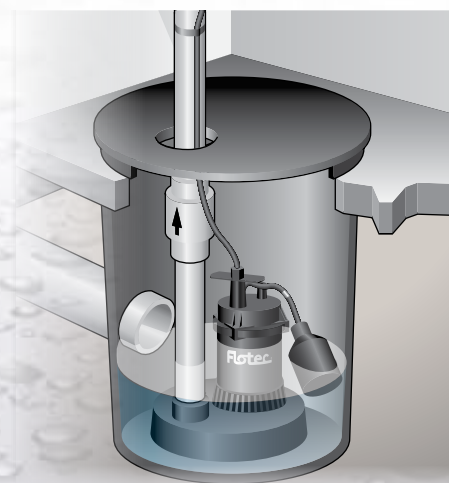

# Thermoplastic Sump Pumps

With Tethered Switch

## Corrosion-Resistant Construction

Designed for years of trouble-free operation

## Tethered Float Switch

Operates in 14" basins and larger



**1/2 HP** 3180 GPH  
FP0S3000A

**1/3 HP** 2880 GPH  
FP0S2000A

PERFORMANCE (GPH)						FLOAT SWITCH		SOLIDS HANDLING
DISCHARGE HEIGHT ABOVE PUMPING LEVEL	0'	10'	20'	25'	MAX. LIFT	ON	OFF	
FP0S3000A	3180	2700	2040	1500	30'	14"	6"	3/8"
FP0S2000A	2880	2460	1800	1200	28'	13"	5.5"	3/8"

MODEL	WARRANTY	UPC	CARTON DIMENSIONS	PALLET QTY.	WEIGHT
FPSC3000A	1 YEAR	022315357051	8.66" x 12.78" x 6.2"	105	13 LBS.
FPSC2000A	1 YEAR	022315357044	8.66" x 12.78" x 6.2"	105	12 LBS.

Includes:

1-1/2" discharge, grounded 8' power cord & detailed owner's manual

Check valve replacement recommended



# Thermoplastic Sump Pump

**With Tethered Switch**

**Corrosion-Resistant Construction**

Designed for years of trouble-free operation

**Tethered Float Switch**

Operates in 14" basins and larger

**Easy Installation**

1-1/4" or 1-1/2" discharge



**1/4 HP 2880 GPH**  
**FP0S1800A**

PERFORMANCE (GPH)						FLOAT SWITCH		SOLIDS HANDLING
DISCHARGE HEIGHT ABOVE PUMPING LEVEL	0'	5'	10'	15'	MAX. LIFT	ON	OFF	
<b>FP0S1800A</b>	2880	2280	1620	660	18'	12.5"	4.5"	1/4"

MODEL	WARRANTY	UPC	CARTON DIMENSIONS	PALLET QTY.	WEIGHT
<b>FP0S1800A</b>	1 YEAR	022315100237	7.94" x 10" x 7.94"	120	7.95 LBS.

Includes:

1-1/4" or 1-1/2" discharge, grounded 8' power cord & detailed owner's manual

Check valve replacement recommended

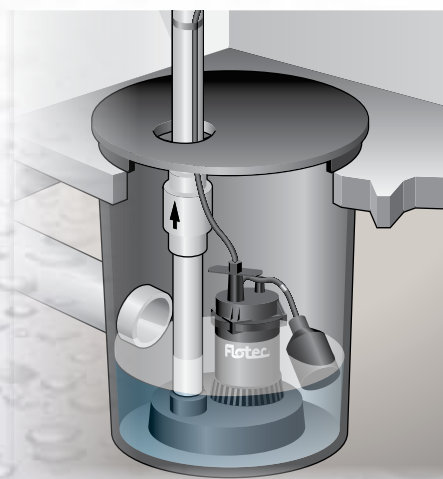

# Non-Submersible Pedestal Sump Pump

**Cast Iron/Stainless Steel**

## High-Output Performance

Pumps up to 4800 gallons per hour

## Heavy-Duty Motor

With thermal overload protection

## Rugged Construction

Cast iron and stainless steel  
corrosion-resistant design



**1/2 HP 4800 GPH**  
**FPPSS5000**

PERFORMANCE (GPH)							FLOAT SWITCH		SOLIDS HANDLING
DISCHARGE HEIGHT ABOVE PUMPING LEVEL	0'	5'	10'	15'	20'	MAX. LIFT	ON	OFF	
<b>FPPSS5000</b>	4800	4200	3830	2720	950	23'	13.7"	4.7"	3/8"

MODEL	WARRANTY	UPC	CARTON DIMENSIONS	PALLET QTY.	WEIGHT
<b>FPPSS5000</b>	2 YEAR	022315171862	8.25" x 7.25" x 34.5"	30	22.3 LBS.

Includes:

Detailed owner's manual

Check valve replacement recommended

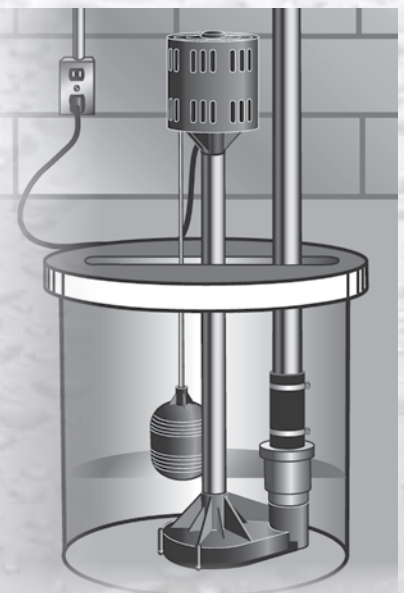

# Non-Submersible Pedestal Sump Pumps

**Thermoplastic or Cast Iron/Stainless Steel**

## Rugged Construction

Designed for a high level of corrosion resistance

## Durable Motor

Thermal overload protection



**1/3 HP 3480 GPH**  
FPPSS3000

**1/3 HP 3480 GPH**  
FPPM3600D

PERFORMANCE (GPH)						FLOAT SWITCH		SOLIDS HANDLING
DISCHARGE HEIGHT ABOVE PUMPING LEVEL	0'	5'	10'	15'	MAX. LIFT	ON	OFF	
<b>FPPSS3000</b>	3480	3200	2700	2000	20'	14"	6"	1/4"
<b>FPPM3600D</b>	3000	3000	2460	1620	20'	14"	6"	1/4"

MODEL	WARRANTY	UPC	CARTON DIMENSIONS	PALLET QTY.	WEIGHT
<b>FPPSS3000</b>	2 YEAR	022315101999	8.25" x 7.25" x 33.5"	30	17.4 LBS.
<b>FPPM3600D</b>	1 YEAR	022315100084	8.25" x 7.25" x 33.5"	30	12.8 LBS.

Includes:

Detailed owner's manual

Check valve replacement recommended

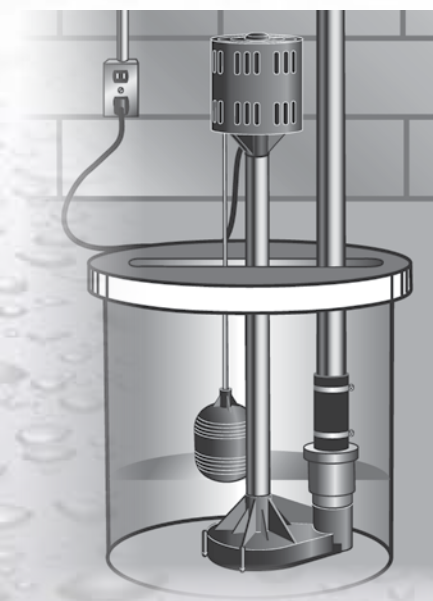

# Self-Contained Sink Pump System

With 1/4 HP Sump Pump

## Under-Sink Basin System

Ideal for pumping washing machine, wet bar and air conditioning drainage without an in-ground basin

## Heavy-Duty

6-gallon structural foam drainage tank

## Easy Installation

Eliminates need for expensive plumbing renovation



**1/4 HP 2880 GPH**  
FP0S1800LTS

PERFORMANCE (GPH)						FLOAT SWITCH		SOLIDS HANDLING
DISCHARGE HEIGHT ABOVE PUMPING LEVEL	0'	5'	10'	15'	MAX. LIFT	ON	OFF	
FP0S1800LTS	2880	2280	1620	660	18'	12.5"	4.5"	1/4"

MODEL	WARRANTY	UPC	CARTON DIMENSIONS	PALLET QTY.	WEIGHT
FP0S1800LTS	1 YEAR	022315101074	15.25" x 13.81" x 15.19"	18	18 LBS.

Includes:

Detailed owner's manual.

Check valve, 1-1/4" x 6-3/4" discharge pipe, basin

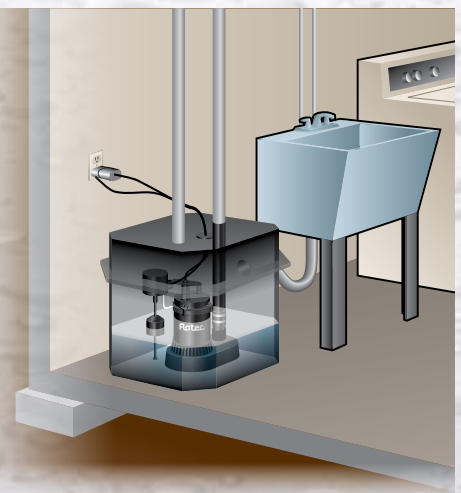

# Under-Sink Mounted Utility Sink Pump

## Complete, Compact System

Perfect for basement wet bars, laundry and utility sinks

## Easy to Install

Eliminates the need for traps, vents and costly labor

## Quiet, Trouble-Free Operation

Easily mounts beneath your sink



**1/4 HP** 1860 GPH  
FPUS1860A

PERFORMANCE (GPH)					
DISCHARGE HEIGHT ABOVE PUMPING LEVEL	0'	3'	5'	7'	10'
FPUS1860A	1860	1740	1620	1440	1200

MODEL	WARRANTY	UPC	CARTON DIMENSIONS	PALLET QTY.	WEIGHT
FPUS1860A	1 YEAR	022315327092	10.4" x 9.4" x 13.6"	60	15.3 LBS.



Includes:

Detailed owner's manual.

1" adapter, 1" ball valve, 1" check valve, 1" 90° elbow, strainer for sink drain, O-ring and gasket seal

## High Performance

# Emergency Battery Backup

## Sump Pump System

### High Performance

Operates automatically in an emergency and runs at full capacity to keep up with incoming water

### Smart Charging Technology

Innovative smart chip technology charges in stages to maintain 90% charge. Prolongs battery life beyond where others fail!

### Audio and Visual Alarms

State-of-the-art diagnostics alert you when system is running, power has failed or system needs maintenance, and warns you if a battery replacement is needed



## Heavy-Duty 3000 GPH

**12V 3000 GPH  
FP2800DCC**

PERFORMANCE (GPH)						CHARGER OUTPUT (AMPS)	SOLIDS HANDLING
DISCHARGE HEIGHT ABOVE PUMPING LEVEL	0'	5'	10'	15'	MAX. LIFT		
<b>FP2800DCC</b>	3000	2550	2000	1000	18'	8.0	3/16"

MODEL	WARRANTY	UPC	CARTON DIMENSIONS	PALLET QTY.	WEIGHT
<b>FP2800DCC</b>	2 YEAR	022315166479	16.9" x 9.6" x 20.3"	24	21.9 LBS.

Includes:

Detailed owner's manual.

Pump mounting tee, check valve for backup pump, fittings for 1-1/4" and 1-1/2" piping, check valve for primary pump





# Emergency Battery Backup

## Sump Pump System

### Power Outage Protection

High-performance pump operates in an emergency to keep up with incoming water

### Smart Charging Technology

Innovative technology charges battery in stages to maintain 90% charge. Prolongs battery life beyond where others fail!

### Optional Dual-Battery Capability

Easily add another battery for ultimate protection and peace of mind

### Dual Check Valves

For connecting to existing sump system



## Built-in Area Light

Lights Up When the Power Goes Out!

**12V** 2000 GPH  
FP1800DCC

PERFORMANCE (GPH)						CHARGER OUTPUT (AMPS)	SOLIDS HANDLING
DISCHARGE HEIGHT ABOVE PUMPING LEVEL	0'	5'	10'	15'	MAX. LIFT		
FP1800DCC	2000	1800	1200	375	16'	2.0	3/16"

MODEL	WARRANTY	UPC	CARTON DIMENSIONS	PALLET QTY.	WEIGHT
FP1800DCC	1 YEAR	022315166462	16.188" x 19.063" x 20.063"	24	11.5 LBS.

Includes:

Detailed owner's manual.

Pump mounting tee, check valve for backup pump, fittings for 1-1/4" and 1-1/2" piping, check valve for primary pump



# Water Powered Emergency Sump Pump

## Backup Sump Pump System

### Added Peace-of-Mind

Automatically relieves sump before a damaging overflow occurs

### No Electricity Needed

Home water pressure is harnessed to create suction draining power

### Compact Design

Fits alongside primary sump pump in basins 10" or larger

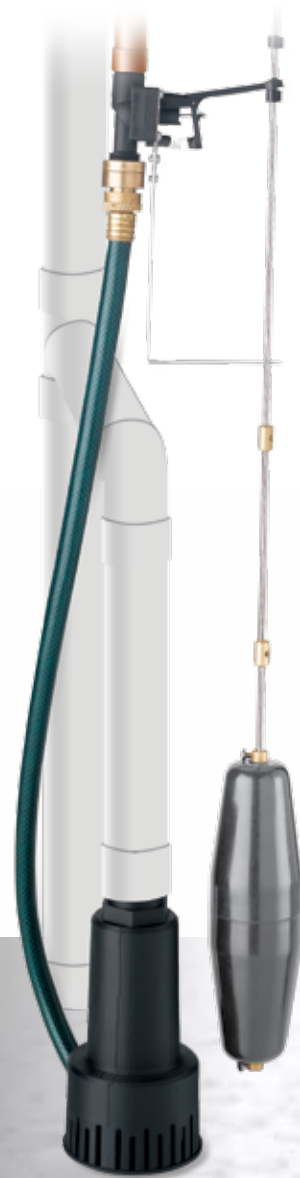

**Uses Municipal Water Pressure  
to Protect Your Basement**

**454 GPH** 60 PSI  
FP480WBU

PERFORMANCE (GPH)					
DISCHARGE HEIGHT ABOVE PUMPING LEVEL	WATER PRESSURE AT INLET WITH VALVE OPEN AND WATER FLOWING	5'	10'	15'	20'
FP480WBU	40 PSI	332	230	127	-
	50 PSI	402	309	217	124
	60 PSI	454	369	285	200

MODEL	WARRANTY	UPC	CARTON DIMENSIONS	PALLET QTY.	WEIGHT
FP480WBU	1 YEAR	022315335288	6" x 6" x 12.4"	144	3.1 LBS.

Includes:

1-1/4" NTP coupling, vacuum breaker, connecting hose, automatic inlet valve, detailed owner's manual

MINIMUM 40 PSI WATER PRESSURE REQUIRED



# Flotec®

## Sewage Pumps

A necessity for homes with basement toilets or washing machines, sewage/effluent pumps lift waste water from the sewage basin up and into the main sewer line. The built-in impeller creates a spinning action in the water to keep solids up to 2" in diameter moving freely.

### Product Line Overview

1/3 HP to 3/4 HP ranges

Stainless Steel and Cast Iron or  
Thermoplastic Construction

Handles solids up to 2" in diameter

All-in-one Sewage Pump System available

Self-contained Sewage System available

1-year to 5-year warranties

### Flotec® PROFESSIONAL

We've taken the best of what contractors have asked for and developed an elite group of products that meet and exceed the requirements of any professional installer. Flotec® Professional pumps are exactly what professional contractors demand!

### PARTS<sub>2</sub>O™ Accessories

Sewage Check Valves:

2" in-line heavy-duty	FPW212-4
2" in-line	FP212-257
18" Sewage Basin	FPW73-15
18" Sewage Basin Lid	FPW73-17



# Cast Iron Sewage Pump

With Tethered Switch

**Flotec**<sup>®</sup>  
PROFESSIONAL

PROFESSIONAL  
PROFESSIONAL

**RUGGED  
CONSTRUCTION**

**HIGH-EFFICIENCY  
PSC MOTOR**

**HANDLES UP TO  
2" SOLIDS**

**5-YEAR WARRANTY**



**170 GPM** 10,200 GPH

MODEL  
E75STVT

**3/4 HP**

Discharge height above pumping level	0'	5'	10'	15'	20'	Max. Lift	Float Switch		Solids Handling	Carton Dimensions	Pallet Quantity	Weight
	Gallons/min. <b>E75STVT</b> Gallons/hr. 022315342187	170 10,200	153 9180	125 7500	105 6300	40 2400	24'	On 16.5"	Off 7.5"	2"	11.5" x 9.88" x 16.13"	32

## PERFORMANCE CURVE

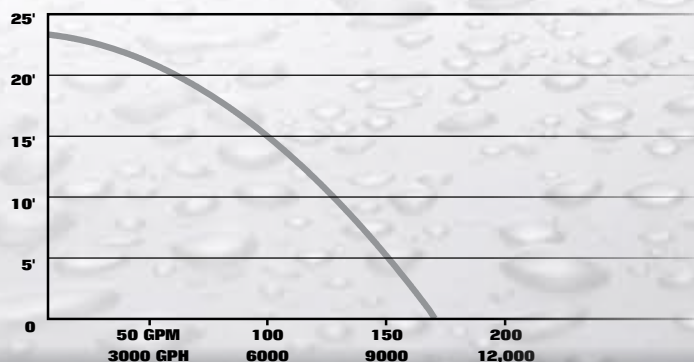

**115VAC 1 Phase**

**10' Power Cord**

**2" FNPT Discharge**

Includes:

2" discharge (meets standard code approvals),  
20' power cord for easy installation,  
detailed owner's manual

Check valve replacement recommended

# Cast Iron Sewage Pump

With Tethered Switch

## High-Output Performance

Pumps up to 9000 gallons per hour

## Rugged Cast Iron Construction

For heavy-duty applications

## Clog-Free Discharge

Handles up to 2" solids

## Tethered Float Switch

Piggyback controls allow for manual operation



**1/2 HP** 9000 GPH  
FPSE3601A

PERFORMANCE (GPH)						FLOAT SWITCH		SOLIDS HANDLING
DISCHARGE HEIGHT ABOVE PUMPING LEVEL	0'	5'	10'	15'	MAX. LIFT	ON	OFF	
<b>FPSE3601A</b>	9000	7320	5400	2700	18'	16.5"	7.5"	2"

MODEL	WARRANTY	UPC	CARTON DIMENSIONS	PALLET QTY.	WEIGHT
<b>FPSE3601A</b>	3 YEAR	022315100350	10.563" x 9.188" x 17.063"	36	36.3 LBS.

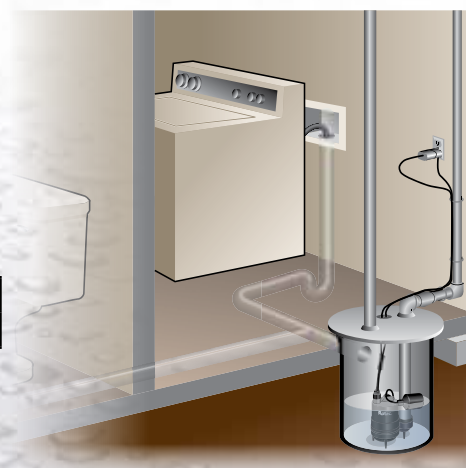

Includes:

2" discharge (meets standard code approvals),  
10' power cord for easy installation,  
detailed owner's manual

Check valve replacement recommended

# Stainless Steel/Thermoplastic Sewage Pump

With Tethered Switch

## High-Output Performance

High-efficiency PSC technology saves operating costs

## Rugged Stainless Steel Construction

Corrosion-resistant thermoplastic base for heavy-duty applications

## Virtually Clog-Free Discharge

Handles up to 2" solids

## Tethered Float Switch

Piggyback controls allow for manual operation



**1/2 HP 9000 GPH**  
FPSE9000

PERFORMANCE (GPH)							FLOAT SWITCH		SOLIDS HANDLING
DISCHARGE HEIGHT ABOVE PUMPING LEVEL	0'	5'	10'	15'	20'	MAX. LIFT	ON	OFF	
FPSE9000	9000	8400	6720	4200	1020	22'	14"	5.5"	2"

MODEL	WARRANTY	UPC	CARTON DIMENSIONS	PALLET QTY.	WEIGHT
FPSE9000	5 YEAR	022315342132	12.2" x 10.6" x 17.4"	24	20.1 LBS.



Includes:

2" discharge (meets standard code approvals),  
10' power cord for easy installation,  
detailed owner's manual

Check valve replacement recommended

# Cast Iron Sewage Pump

With Tethered Switch

## Rugged Cast Iron Construction

For heavy-duty applications

## Virtually Clog-Free Discharge

Handles up to 2" solids

## Tethered Float Switch

Piggyback controls allow for manual operation



**1/2 HP** 5250 GPH  
FPSE3500A

PERFORMANCE (GPH)						FLOAT SWITCH		SOLIDS HANDLING
DISCHARGE HEIGHT ABOVE PUMPING LEVEL	0'	5'	10'	15'	MAX. LIFT	ON	OFF	
<b>FPSE3500A</b>	5250	4800	3200	1800	18'	17"	10"	2"

MODEL	WARRANTY	UPC	CARTON DIMENSIONS	PALLET QTY.	WEIGHT
<b>FPSE3500A</b>	1 YEAR	022315357006	11.31" x 8.125" x 16.125"	80	31 LBS.

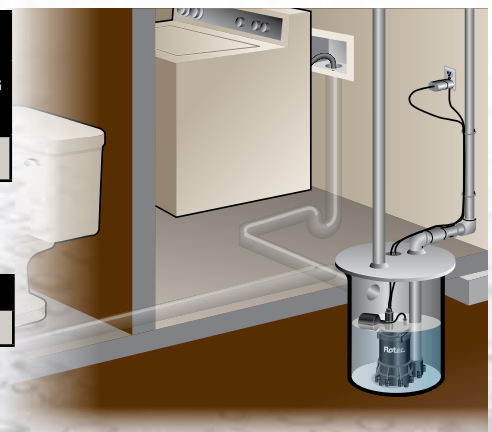

Includes:

2" discharge (meets standard code approvals),  
8' power cord for easy installation,  
detailed owner's manual

Check valve replacement recommended

# Thermoplastic Sewage Pump

With Tethered Switch

## Handles up to 2" Solids

Virtually clog-free discharge

## Thermoplastic Construction

For corrosion resistance

## High-Efficiency Motor

With overload protection

## Tethered Float Switch

Piggyback controls allow for manual operation



**4/10 HP** 5250 GPH  
FPSE3200A

PERFORMANCE (GPH)						FLOAT SWITCH		SOLIDS HANDLING
DISCHARGE HEIGHT ABOVE PUMPING LEVEL	0'	5'	10'	15'	MAX. LIFT	ON	OFF	
<b>FPSE3200A</b>	5250	3900	2550	960	18'	17.25"	9.5"	2"

MODEL	WARRANTY	UPC	CARTON DIMENSIONS	PALLET QTY.	WEIGHT
<b>FPSE3200A</b>	1 YEAR	022315102019	10.5" x 16.3" x 7.1"	50	12 LBS.

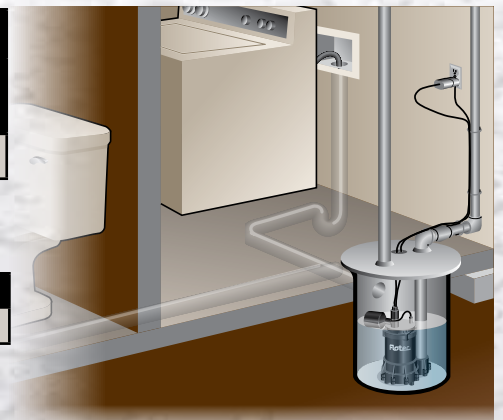

Includes:

2" discharge (meets standard code approvals),  
10' power cord for easy installation,  
detailed owner's manual

Check valve replacement recommended



# Thermoplastic Effluent Pump

With Tethered Switch

**Handles up to 3/4" Solids**

Virtually clog-free discharge

**Thermoplastic Construction**

For corrosion resistance

**High-Efficiency Motor**

With overload protection

**Tethered Float Switch**

Piggyback controls allow for manual operation



**1/3 HP 3600 GPH**  
**FPSE2800A**

PERFORMANCE (GPH)								FLOAT SWITCH		SOLIDS HANDLING
DISCHARGE HEIGHT ABOVE PUMPING LEVEL	0'	5'	10'	15'	20'	25'	MAX. LIFT	ON	OFF	
<b>FPSE2800A</b>	3600	3180	2700	2100	1500	750	29'	14.75"	7.5"	3/4"

MODEL	WARRANTY	UPC	CARTON DIMENSIONS	PALLET QTY.	WEIGHT
<b>FPSE2800A</b>	1 YEAR	022315102026	10.5" x 16.3" x 7.1"	50	13.35 LBS.

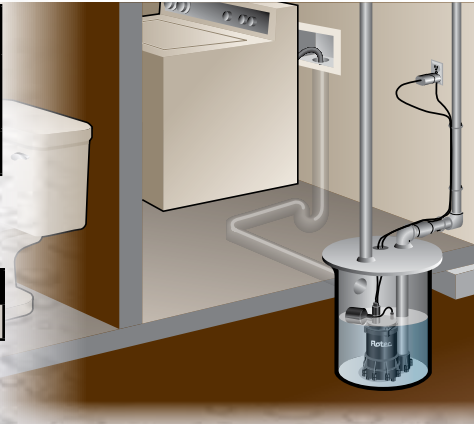

Includes:

- 1-1/2" discharge (meets standard code approvals),
- 15' power cord for easy installation,
- detailed owner's manual

Check valve replacement recommended

# Complete Sewage Pump System

**With 4/10 HP Sewage Pump**

**All-in-One System**

Includes basin, lid cover, check valve and pump

**Virtually Clog-Free Discharge**

Handles up to 2" solids

**Thermoplastic Construction**

For corrosion resistance

**Durable Oil-Cooled 115-Volt Motor**

With overload protection



**4/10 HP** 5250 GPH  
FP400C

PERFORMANCE (GPH)						FLOAT SWITCH		SOLIDS HANDLING
DISCHARGE HEIGHT ABOVE PUMPING LEVEL	0'	5'	10'	15'	MAX. LIFT	ON	OFF	
<b>FP400C</b>	5250	3900	2550	960	18'	17.25"	9.5"	2"

MODEL	WARRANTY	UPC	CARTON DIMENSIONS	PALLET QTY.	WEIGHT
<b>FP400C</b>	1 YEAR	022315137271	18" x 30" x 18"	4	29.75 LBS.

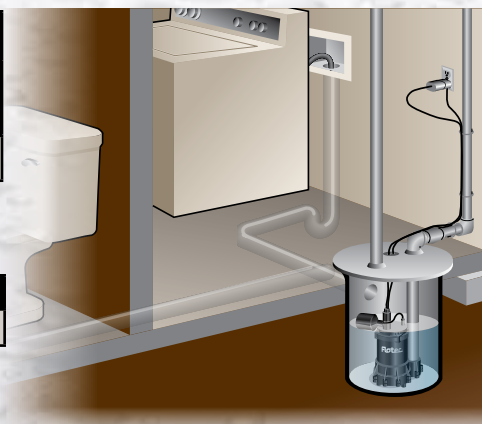

Includes:

2" discharge (meets standard code approvals), 8' power cord, detailed owner's manual, and check valve.

# Add-A-Jon Toilet Kit

## Self-Contained Toilet Pump System

### Below-Grade Sewage System without In-Ground Basin

Ideal for installing a toilet, vanity or shower without an in-ground sewage basin

### Powerful 1/2 HP Sewage Pump

With automatic switch, 2" discharge and check valve assembly

### Fits Almost Anywhere

Ideal for basements, room additions, factories and warehouses

### Concrete Floor Stays Intact

Can be installed freestanding on top of any level surface



## 1/2 HP 9000 GPH FP450C

PERFORMANCE (GPH)							FLOAT SWITCH		SOLIDS HANDLING
DISCHARGE HEIGHT ABOVE PUMPING LEVEL	0'	5'	10'	15'	20'	MAX. LIFT	ON	OFF	
FP450C	9000	8400	6720	4200	1020	22'	14"	5.5"	2"

MODEL	WARRANTY	UPC	CARTON DIMENSIONS	PALLET QTY.	WEIGHT
FP450C	1 YEAR	022315321021	40" x 24" x 22.5"	8	29.75 LBS.

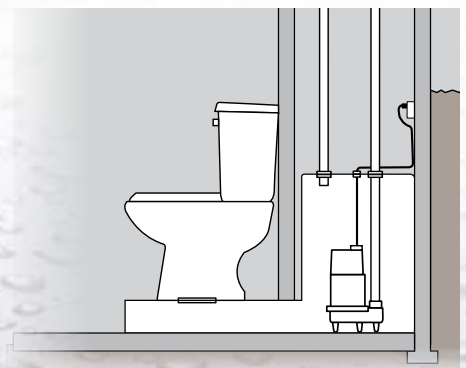

#### Includes:

Check valve, pipe grommet, cord grommet, discharge pipe, adapter, foam gasket, detailed owner's manual

# Flotec®

## Utility Pumps

In an emergency, a utility pump is the pump you need to have on hand. Perfect for removing water from window wells, rooftops, flooded areas or for draining sinks, aquariums and water beds. Utility pumps excel at moving water quickly and efficiently from place to place.

### Product Line Overview

1/6 HP to 5-1/2 HP ranges

Cast Aluminum, Stainless Steel and Thermoplastic Construction

Submersible and non-submersible products

Portable transfer products

Garden waterfall pumps

Gas engine pumps



### PARTS<sub>2</sub>O™ Accessories

Drill Pump	FPDMP21SA
Drill Pump & Hose Kit	FPDMP21HC
2" Heavy-Duty Discharge Hose	FP2731
2" Reinforced Suction Hose	FP2735
High-Pressure Hose	FPBPH
High-Pressure Spray Nozzle	FPBPN

# Thermoplastic Utility Pump

*IntelliPump*<sup>™</sup>  
series

## Automatic Operation

### Automatically Checks for Water

Detects water at 3/4" and pumps down to 1/4"

### Innovative Electronic Monitoring

Pump starts every 2-1/2 minutes to check for water.  
Shuts off if water is not detected

### Easy, Portable Operation

Attach 5/8" garden hose then just plug in.

### Wide Range of Applications

For basements, rooftops, window wells or any regularly flooded area



## Water Sensor

Automatically Checks for Water

**1/4 HP** 1790 GPH  
FP0S1775A

PERFORMANCE (GPH)								HP
DISCHARGE HEIGHT ABOVE PUMPING LEVEL	0'	3'	5'	10'	15'	20'	MAX. LIFT	
FP0S1775A	1790	1600	1524	1260	924	372	22'	1/4



MODEL	WARRANTY	UPC	CARTON DIMENSIONS	PALLET QTY.	WEIGHT
FP0S1775A	2 YEAR	022315170315	8.09" x 11.81" x 6.09"	108	8.25 LBS.

Includes:

15' power cord, garden hose adapter, detailed owner's manual

# Thermoplastic Utility Pumps

## Submersible

### High-Output Performance

For removing unwanted water down to 3/16" depth

### Thermoplastic Construction

For the highest corrosion-resistance

### Portable and Versatile

Use in window wells, basements, rooftops, etc.

### Removable Inlet Screen

For easy cleaning



**1/4 HP** 1790 GPH  
FP0S1600X

**1/6 HP** 1470 GPH  
FP0S1300X

PERFORMANCE (GPH)							HP
DISCHARGE HEIGHT ABOVE PUMPING LEVEL	0'	5'	10'	15'	20'	MAX. LIFT	
FP0S1600X	1790	1524	1260	924	372	22'	1/4
FP0S1300X	1470	1250	930	660	-	20'	1/6



MODEL	WARRANTY	UPC	CARTON DIMENSIONS	PALLET QTY.	WEIGHT
FP0S1600X	1 YEAR	022315138230	6.5" x 6.5" x 9.875"	168	7.4 LBS.
FP0S1300X	1 YEAR	022315100022	6.5" x 6.5" x 9.875"	168	6.4 LBS.

Includes:

8' power cord, garden hose adapter, detailed owner's manual

# Cast Aluminum Utility Pump

**Submersible**

**Heavy-Duty Construction**

Epoxy-coated, cast aluminum housing

**Extra-Large 1-1/4" Discharge**

**Easy, Portable Operation**

Attach 5/8" garden hose then just plug in.

**Multi-Purpose Pump**

For basements, rooftops, window wells or any flooded area



**1/4 HP** 1320 GPH  
FPSC1725X

PERFORMANCE (GPH)							HP
DISCHARGE HEIGHT ABOVE PUMPING LEVEL	0'	5'	10'	15'	20'	MAX. LIFT	
FPSC1725X	1320	1170	1020	810	510	25'	1/4



MODEL	WARRANTY	UPC	CARTON DIMENSIONS	PALLET QTY.	WEIGHT
FPSC1725X	3 YEAR	022315171855	6.44" x 11.92" x 6.44"	120	9.5 LBS.

Includes:

8' power cord, garden hose adapter, detailed owner's manual

# Thermoplastic Utility Pump

**Submersible**

**General Purpose Pump**

For removing unwanted water to 3/16" depth

**Thermoplastic Construction**

For the highest corrosion-resistance

**Portable and Versatile**

Use where unwanted water collects

**8' Power Cord Included**



**1/6 HP 1200 GPH**  
FP0S1250X

PERFORMANCE (GPH)							HP
DISCHARGE HEIGHT ABOVE PUMPING LEVEL	0'	3'	5'	10'	15'	MAX. LIFT	
FP0S1250X	1200	1140	1050	840	480	20'	1/6

MODEL	WARRANTY	UPC	CARTON DIMENSIONS	PALLET QTY.	WEIGHT
FP0S1250X	1 YEAR	022315100015	6.44" x 10.19" x 6.44"	168	5.9 LBS.



Includes:

8' power cord, garden hose adapter, detailed owner's manual



# Stainless Steel Utility/ Waterfall Pump

## Submersible

### Superior Performance

Pumps up to 4100 gallons per hour

### Complete Stainless Steel Construction

For superior corrosion-resistance

### Oil-Free Motor

Safe for fish and plants

### Dual Ball-Bearing Design

Quiet, durable and long-lasting

### Premium Ceramic Seal Design

Allows for continuous operation



**1/2 HP 4100 GPH**  
FP0S4100X

PERFORMANCE (GPH)								HP	OUTLET
DISCHARGE HEIGHT ABOVE PUMPING LEVEL	0'	5'	10'	15'	20'	25'	MAX. LIFT		
FP0S4100X	4100	3600	3000	2400	1650	900	30'	1/2	1-1/4" with multiple fittings

MODEL	WARRANTY	UPC	CARTON DIMENSIONS	PALLET QTY.	WEIGHT
FP0S4100X	2 YEAR	022315164826	7.36" x 14.17" x 7.36"	48	17 LBS.



Includes:

Stainless steel impeller, 15' grounded power cord, 1-1/4" x 1" NPT adapter, detailed owner's manual

# Thermoplastic Utility/ Waterfall Pump

## Submersible

### High-Output Performance

Pumps up to 3000 gallons per hour

### Thermoplastic Construction

Designed for years of trouble-free operation

### Oil-Free Motor

Safe for fish and plants

### Ceramic Seal Design

Allows for continuous operation



**4/10 HP** 3000 GPH  
FP0S3000X

PERFORMANCE (GPH)							HP	OUTLET
DISCHARGE HEIGHT ABOVE PUMPING LEVEL	0'	5'	10'	15'	20'	MAX. LIFT		
FP0S3000X	3000	2500	1900	1320	750	25'	4/10	1-1/4" with multiple fittings

MODEL	WARRANTY	UPC	CARTON DIMENSIONS	PALLET QTY.	WEIGHT
FP0S3000X	1 YEAR	022315164819	6.44" x 11.8" x 6.44"	90	9.6 LBS.

Includes:

Three discharge fittings: 1/2", 3/4" and 1" barbed hose, 1" reducer, garden hose adapter



# Thermoplastic Pool Cover/ Utility Pump

With Removable Base

## Multi-Purpose Versatility

Great for pools & covers, spas, basements, or removing any standing water

## Removable 'Cover-Cruiser' Base

Glides pump to low standing water; filters leaves and other debris for smooth operation

## Rotor Protection with Instant Reset

Guards against ice-lock or blocked impeller for longer life

## Easy to Use

Includes 25' power cord with GFCI plug and 90° garden hose adapter



## Water Sensor

Automatically Checks for Water

**1/4 HP** 1790 GPH  
FP0S1790PCA

PERFORMANCE (GPH)								HP
DISCHARGE HEIGHT ABOVE PUMPING LEVEL	0'	3'	5'	10'	15'	20'	MAX. LIFT	
FP0S1790PCA	1790	1600	1524	1260	924	372	22'	1/4

MODEL	WARRANTY	UPC	CARTON DIMENSIONS	PALLET QTY.	WEIGHT
FP0S1790PCA	2 YEAR	022315337145	12.06" x 12.1" x 9.03"	45	8 LBS.

Includes:

25' power cord with GFCI plug, 90° garden hose adapter, detailed owner's manual

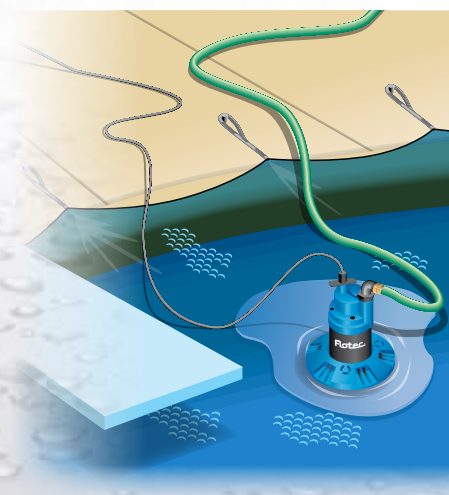

# Thermoplastic Utility Pump

Portable/Transfer

## Water Transfer/ Pressure Booster

Use as a water transfer, pressure booster or portable sprinkler pump

## Thermoplastic Construction

For the highest corrosion-resistance

## Increase Water Pressure

For washing vehicles, equipment, sprinkling and more

## Sprinkler Pump Operation

Transfer surface water from natural sources for landscape irrigation



**1/2 HP 10.3 GPM**  
FP5112

PERFORMANCE (GPM)							MAX. LIFT	MAX. PSI
DISCHARGE HEIGHT ABOVE PUMPING LEVEL	0'	5'	10'	15'	20'	25'		
<b>FP5112</b>	10.3	6.1	5.1	4.2	3.9	3	26'	62

WARRANTY	UPC	CARTON DIMENSIONS	PALLET QTY.	WEIGHT
1 YEAR	022315138315	14.4" x 11.2" x 8.4"	30	16.8 LBS.



Includes:

Detailed owner's manual.

6' power cord, garden hose adapters, 1" threaded suction and discharge

# Transfer Utility Pumps

AC or DC Operation

## Multi-Purpose Pumps

For emergency dewatering, waterbeds, clogged sinks, aquariums and boat bottoms

## Compact and Portable

Easy setup, easy to use

## PUD-L-SCOOP® Attachment

Pumps water down to 1/8"

## Corrosion-Resistant

Thermoplastic impeller housing



**1/12 HP** 350 GPH  
FPOF360AC

**12V** 450 GPH  
FPOFDC

PERFORMANCE (GPH)							MAXIMUM LIFT
DISCHARGE HEIGHT ABOVE PUMPING LEVEL	0'	5'	10'	20'	30'	40'	
<b>FPOF360AC</b>	350	330	300	240	145	62	43'
<b>FPOFDC</b>	450	435	390	300	225	130	45'

MODEL	WARRANTY	UPC	CARTON DIMENSIONS	PALLET QTY.	WEIGHT
<b>FPOF360AC</b>	90 DAY	022315100169	6.5" x 6.5" x 11"	168	6.4 LBS.
<b>FPOFDC</b>	90 DAY	022315357716	6.5" x 6.5" x 11"	168	8.210 LBS.

Includes:

6' power cord, PUD-L-SCOOP® suction attachment, oil primer packets  
Detailed owner's manual



# Heating/Cooling System Condensate Pumps

## Ideal for Furnace or Air Conditioner

Automatic, maintenance-free operation

## Safety Switch

Provides automatic shutoff

## Corrosion-Resistant Construction

Designed for years of trouble-free operation

## 20' Tubing Kit Included

For quick, easy installation  
(FPCP-20ULST only)



**2 QT** 200 GPH  
FPCP-20ULST

**2 QT** 120 GPH  
FPCP-15ULS

PERFORMANCE (GPH)					MAXIMUM LIFT
DISCHARGE HEIGHT ABOVE PUMPING LEVEL	0'	5'	10'	15'	
FPCP-20ULST	200	150	100	30	18.5'
FPCP-15ULS	120	90	65	0	15'

MODEL	WARRANTY	UPC	CARTON DIMS.	PALLET QTY.	WEIGHT
FPCP-20ULST	2 YEAR	022315164932	10.41" x 5.16" x 5.43"	196	4.3 LBS.
FPCP-15ULS	1 YEAR	022315164949	10.41" x 5.16" x 8.46"	140	5.5 LBS.

Includes:

6' power cord, (20') 3/8" I.D. tubing, detailed owner's manual



# Gas-Powered HydroBlaster®

## High-Volume Utility Pump

### Typical Application

Excellent for floodwater removal and remote irrigation where water lines and electricity are not available

### Easy Portability

Portable unit with rugged carrying handle for water transfer in remote locations

### Heavy-Duty Gas Engine Motor

With automatic low-oil safety cutoff, manual throttle choke and engine shutoff controls



**5.5 HP** 141 GPM  
FP5455

PERFORMANCE						
DISTANCE TO PUMP ABOVE WATER	GALLONS PER MINUTE AT DISCHARGE PRESSURE (PSI)					MAX PSI
	15	25	35	45	50	
0'	141	120	95	65	50	58
5'	130	110	85	55	40	55
10'	121	100	75	45	25	52
15'	113	90	65	30	2	50
20'	105	80	55	7	-	48
25'	80	60	40	2	-	45

WARRANTY	UPC	CARTON DIMENSIONS	PALLET QTY.	WEIGHT
1 YEAR	022315313941	21" x 14.5" x 18"	12	48.9 LBS.



Detailed owner's manual

# Flotec®

## Pool Pumps

Whether you are circulating water for an in-ground or above-ground pool, Flotec has the right product for you. Our corrosion-resistant pool pumps are constructed of rugged, heavy-duty fiberglass-reinforced thermoplastic to stand up to seasonal changes.

### Product Line Overview

Thermoplastic Pool Pumps from  
1 HP to 1-1/2 HP



### Calculate Your Pool Size



$$\begin{array}{l}
 3.14 \\
 \times \text{1/2 Diameter} \\
 \times \text{1/2 Diameter} \\
 \times \text{Depth} \\
 \hline
 \times 7.5^* \\
 \hline
 = \text{Total Capacity} \\
 \text{in Gallons}
 \end{array}$$



$$\begin{array}{l}
 \text{Length} \\
 \times \text{Width} \\
 \times \text{Depth} \\
 \hline
 = \text{Cubic feet} \\
 \hline
 \times 7.5^* \\
 \hline
 = \text{Total Capacity} \\
 \text{in Gallons}
 \end{array}$$

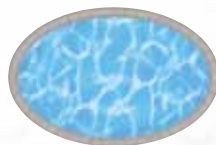

$$\begin{array}{l}
 \text{Length} \\
 \times \text{Width} \\
 \times \text{Depth} \\
 \hline
 = \text{Cubic feet} \\
 \hline
 \times 7.5^* \\
 \hline
 = \text{Total Capacity} \\
 \text{in Gallons}
 \end{array}$$

\* The factor for determining the number of gallons in a cubic foot.

**PARTS<sub>2</sub>O™ Accessories**

Union Fitting

AT741603



# In-Ground & Above-Ground Pool Pumps

## High Performance

Designed to move large amounts of water

## Extremely Quiet

Specially designed bases dampen sound and vibration

## Low Maintenance

Extra-large capacity traps with see-through lid

## Easy Installation

For use with in-ground or above-ground pools, includes quick-connect union

## Heavy-Duty Dual-Voltage Motor

Preset at 230V

## Easy-Open Drain Plug

Makes for tool-free winterizing and service

## 1-Year Warranty



**1-1/2 HP** UP TO 52,800 GAL  
AT251501

**1 HP** UP TO 43,200 GAL  
AT251001

PERFORMANCE																
MODEL/UPC	HP	FOR POOLS UP TO (GAL.)	VOLTS	DISCHARGE HEIGHT ABOVE PUMPING LEVEL								SLIP FIT PIPE SIZE		CARTON DIMS. (IN INCHES)	WT. (LBS.)	
				25'	30'	35'	40'	45'	50'	55'	60'	SUCTION	DISCH.			
<b>AT251501</b> 022315207233	<b>1-1/2</b>	<b>52,800</b>	230/115	-	-	112	107	99	90	81	72	1-1/2"	1-1/2"	27 x 13 x 16 18/PALLET	39	
<b>AT251001</b> 0223151207226	<b>1</b>	<b>43,200</b>	230/115	-	-	86	80	69	60	50	-	1-1/2"	1-1/2"	27 x 13 x 16 18/PALLET	35.2	

Includes:  
Detailed owner's manual



# Sprinkler & Centrifugal Pumps

When irrigating your lawn or moving large volumes of water, Flotec has the right product for you. Our corrosion-resistant sprinkler pumps are constructed of rugged, heavy-duty fiberglass-reinforced thermoplastic or rugged cast iron to stand up to seasonal changes.

## Sprinkler Applications

Sprinkler systems that have single/multiple zones with more than 2-3 heads per zone, requiring greater than 20 gallons per minute. Movement of large volumes of water from water source to place of use.

## Centrifugal Applications

Economical, general purpose centrifugal pumps can be used for water transfer, circulation, fountains, waterfalls, pressure boosting and sprinkling.

## Product Line Overview

**Cast iron and thermoplastic pumps available**

**Cast iron centrifugal pumps  
from 1/2 HP to 1 HP**

**1-year warranty on pumps**



## **PARTS<sub>2</sub>O™** Accessories

For a complete line of well pump and tank accessories see pages 78–81.



# Thermoplastic Sprinkler Pumps

## Superior Performance

At depths to water of 20' or less

## Fiberglass-Reinforced Thermoplastic Pump Housing

For the highest corrosion resistance

## High Capacity

Ideal for larger sprinkler zones or water transfer with 1-1/2" or 2" tapping for suction and discharge

## Heavy-Duty Dual-Voltage Motor

Preset at 230V

## Self-Priming After Pump Housing Is Initially Filled

Check valve or foot valve required, sold separately

## 1-Year Warranty

Includes:

Threaded ports for pressure gauge and drain plug, detailed owner's manual



**2 HP** 69 GPM  
FP5182

**1-1/2 HP** 67 GPM  
FP5172

**1 HP** 55 GPM  
FP5162

PERFORMANCE																		
MODEL/UPC	HP	GPM	VOLTS	DISTANCE OF PUMP ABOVE WATER	DISCHARGE PRESSURE (PSI)										NPT PIPE SIZE		CARTON DIMS. (IN INCHES)	WT. (LBS.)
					10	15	20	25	30	35	40	45	50	SUCTION	DISCH.			
<b>FP5182</b> 022315100725	<b>2</b>	<b>69</b>	230/115	5'	69	64	59	53	47	40	34	24	14	2"	2"	21.563 x 12.813 x 15.375 18/PALLET	42	
				10'	67	62	56	50	45	38	30	18	7					
				15'	65	60	54	48	42	35	27	13	-					
				20'	62	57	52	46	40	32	23	10	-					
<b>FP5172</b> 022315100718	<b>1-1/2</b>	<b>67</b>	230/115	5'	67	66	61	55	48	39	33	18	-	1-1/2"	1-1/2"	21.813 x 12.313 x 13.125 24/PALLET	34.1	
				10'	61	58	56	52	45	37	27	14	-					
				15'	56	55	54	51	44	34	20	8	-					
				20'	46	45	44	43	37	28	11	-	-					
<b>FP5162</b> 022315100701	<b>1</b>	<b>55</b>	230/115	5'	55	51	45	38	31	23	17	-	-	1-1/2"	1-1/2"	21.813 x 12.313 x 13.125 24/PALLET	30.6	
				10'	49	46	42	35	28	19	13	-	-					
				15'	48	45	39	32	24	16	8	-	-					
				20'	45	44	37	29	20	11	-	-	-					

\* Performance shown in gallons per minute

# Cast Iron Sprinkler Pumps

## Rugged Pump Housing

Durable, cast iron construction

## Superior Performance

At depths to water of 25' or less

## High Capacity

Ideal for larger sprinkler zones or water transfer

## Heavy-Duty Dual-Voltage Motor

Preset at 230V

## Self-Priming After Pump Housing Is Initially Filled

Check valve or foot valve required, sold separately

## Drain Port Provided

For convenient winterizing

## 1-Year Warranty



**2 HP** 64 GPM  
FP5252

**1-1/2 HP** 55 GPM  
FP5242

PERFORMANCE															
MODEL/UPC	HP	GPM	VOLTS	DISTANCE OF PUMP ABOVE WATER	DISCHARGE PRESSURE (PSI)							NPT PIPE SIZE		CARTON DIMS. (IN INCHES)	WT. (LBS.)
					20	25	30	35	40	45	50	SUCTION	DISCH.		
FP5252 022315162808	2	64	230/115	5'	64	58	53	45	38	28	19	2"	2"	24.063 x 17.938 x 13.563 12/PALLET	86.2
				10'	62	56	50	42	35	24	13				
				15'	59	53	47	39	31	20	-				
				20'	57	50	44	35	26	-	-				
				25'	51	44	38	30	20	-	-				
FP5242 022315162792	1-1/2	55	230/115	5'	55	50	45	28	31	20	-	2"	1-1/2"	24.063 x 17.938 x 13.563 12/PALLET	71.4
				10'	53	47	42	34	27	16	-				
				15'	51	45	39	30	22	-	-				
				20'	49	42	36	27	18	-	-				
				25'	46	39	32	22	12	-	-				

Includes:  
Threaded ports for pressure gauge and drain plug, detailed owner's manual

# Cast Iron Centrifugal Pumps

## Rugged Pump Housing

Durable, cast iron construction

## Superior Performance

At depths to water of 25' or less

## Heavy-Duty Dual-Voltage Motor

Preset at 230V

## Easy Installation

Discharge can be rotated to horizontal or vertical installations

## 1-Year Warranty



**1 HP** 69 GPM  
FP5532

**3/4 HP** 67 GPM  
FP5522

**1/2 HP** 55 GPM  
FP5512

PERFORMANCE												
MODEL/UPC	HP	MAX. PRESS.	VOLTS	DISCHARGE PRESSURE (PSI)					NPT PIPE SIZE		CARTON DIMS. (IN INCHES)	WT. (LBS.)
				25	30	35	40	45	SUCTION	DISCH.		
<b>FP5532</b> 022315135949	<b>1</b>	<b>49</b>	230/115	47	40	35	29	17	1-1/4"	1"	19.813 x 10.063 x 10.818 40/PALLET	41.2
<b>FP5522</b> 022315135932	<b>3/4</b>	<b>43</b>	230/115	31	25	21	13	-	1-1/4"	1"	19.813 x 10.063 x 10.818 32/PALLET	32.15
<b>FP5512</b> 022315135925	<b>1/2</b>	<b>36</b>	230/115	22	13	2	-	-	1-1/4"	1"	19.813 x 10.063 x 10.818 32/PALLET	30.10

Includes:  
Threaded ports for pressure gauge and drain plug, detailed owner's manual

# Flotec®

## Well Pumps

In rural areas where city water isn't available, well pumps are used to pump water from below the ground. Tanks are used to store the water, which increases the life of a pump by reducing the number of cycles and maintains water pressure throughout the home. So whether you are replacing an existing well system or installing a new one, Flotec has the pump for you.

### Product Line Overview

#### Jet Pumps

Up to 21 GPM

Complete jet/tank pump systems available

Cast iron or thermoplastic construction

5' to 500' well depths

1-year warranty on pumps

2-wire 4" subs

1/2 HP - 1 HP available

3-year warranty

3-wire 4" subs

1/2 HP - 1HP available

3-year warranty

#### Pressure Tanks

Heavy-gauge steel tanks for maximum durability

Factory precharged for convenience

5-year warranty on tanks



### PARTS<sub>2</sub>O™ Accessories

For a complete line of well pump and tank accessories see pages 78-81.

# Well Pump Application

## 4" SUBMERSIBLE

### Pitless Adapter Installation

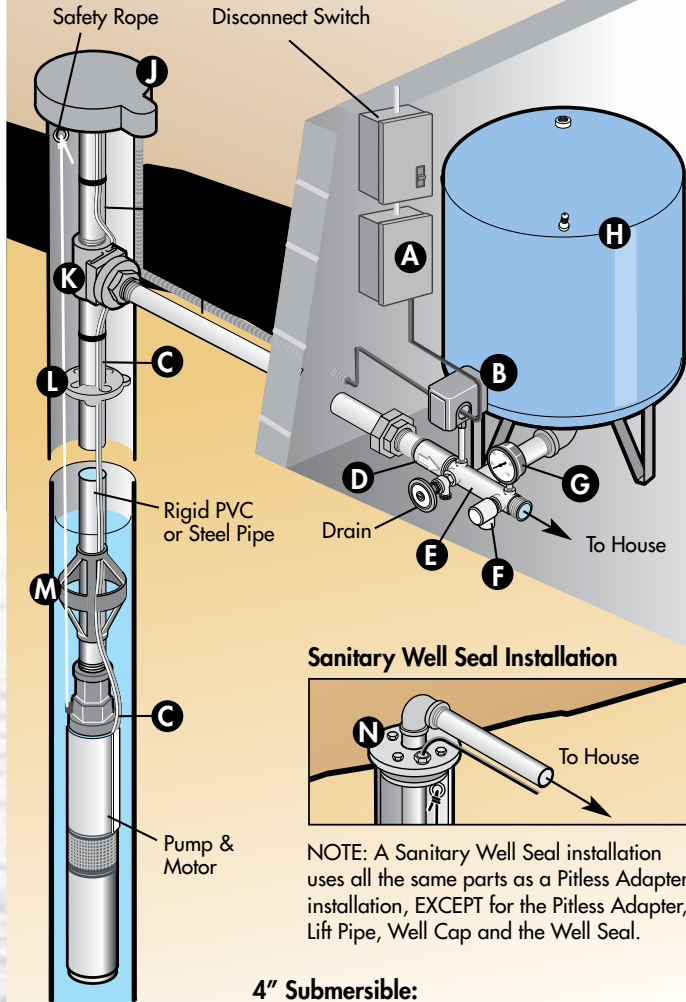

### Sanitary Well Seal Installation

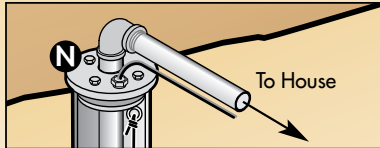

NOTE: A Sanitary Well Seal installation uses all the same parts as a Pitless Adapter installation, EXCEPT for the Pitless Adapter, Lift Pipe, Well Cap and the Well Seal.

### 4" Submersible:

- |                             |                   |
|-----------------------------|-------------------|
| A 3 Wire Pump Control Box   | J Well Cap        |
| B Pressure Switch           | K Pitless Adapter |
| C Pipe                      | L Cable Protector |
| D Check Valve               | M Torque Arrestor |
| E Tank Tee                  | N Well Seal       |
| F Pressure Relief Valve     |                   |
| G Pressure Gauge            |                   |
| H Pre-charged Pressure Tank |                   |

## SHALLOW WELL

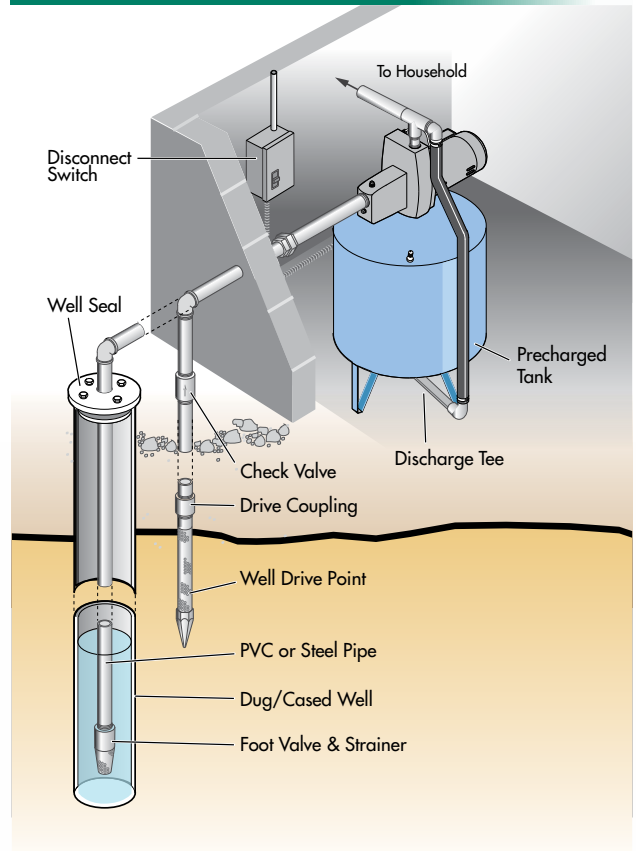

## DEEP WELL

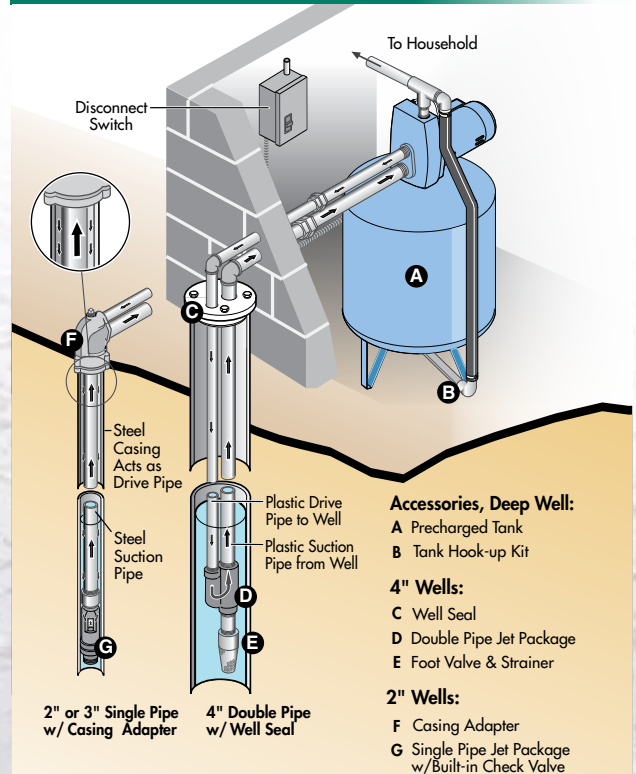

### Accessories, Deep Well:

- |                           |
|---------------------------|
| A Precharged Tank         |
| B Tank Hook-up Kit        |
| 4" Wells:                 |
| C Well Seal               |
| D Double Pipe Jet Package |
| E Foot Valve & Strainer   |

### 2" Wells:

- |  |
|--|
| F Casing Adapter                                 |
| G Single Pipe Jet Package w/Built-in Check Valve |

2" or 3" Single Pipe w/ Casing Adapter

4" Double Pipe w/ Well Seal

# Thermoplastic Shallow Well Jet Pumps

**With Built-in Pressure Switch**

## Superior Performance

At depths to water of 25' or less

## Fiberglass-Reinforced Thermoplastic Pump Housing

For the highest corrosion-resistance

## Heavy-Duty Dual-Voltage Motor

1/2 HP preset at 115V; 3/4 HP & 1 HP preset at 230V

## Self-Priming After Pump Housing Is Initially Filled

Check valve or foot valve required, sold separately



<b>1 HP</b> 18 GPM FP4032	<b>3/4 HP</b> 12 GPM FP4022	<b>1/2 HP</b> 8 GPM FP4012
------------------------------	--------------------------------	-------------------------------

PERFORMANCE (GPM)	DEPTH TO WATER						MAX PRESSURE SHUTOFF	VOLTAGE	PRESS. SWITCH	
	0'	5'	10'	15'	20'	25'			ON	OFF
<b>FP4032</b>	18	16.4	16.1	14.1	12.0	8.1	67 PSI	115/230	30	50
<b>FP4022</b>	12	10.3	9.7	8.2	7.1	5.1	78 PSI	115/230	30	50
<b>FP4012</b>	8	7.4	6.4	6.1	5.1	4.0	77 PSI	115/230	30	50

All performances shown in gallons per minute at 40 PSI discharge pressure.

MODEL	WARRANTY	UPC	CARTON DIMENSIONS	PALLET QTY.	WEIGHT
<b>FP4032</b>	1 YEAR	022315315150	22.813" x 11.063" x 10.5"	24	29.15 LBS.
<b>FP4022</b>	1 YEAR	022315100589	22.813" x 11.063" x 10.5"	24	26.9 LBS.
<b>FP4012</b>	1 YEAR	022315100572	22.813" x 11.063" x 10.5"	24	23 LBS.

Includes:

Factory-installed 30/50 preset pressure switch, detailed owner's manual

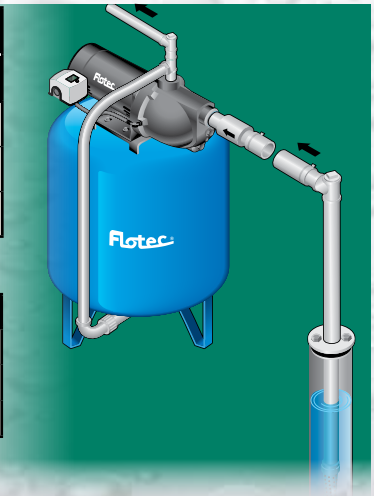



# Complete Jet & Tank System

**With Thermoplastic Pump**

**Ideal for Compact Installations**

Where space is at a premium

**Superior Performance**

At depths to water of 25' or less

**Precharged Pressure Tank with 15-Gallon Equivalent Capacity**

Corrosion-resistant, heavy-gauge steel construction with baked-on finish

**Fiberglass Reinforced Thermoplastic Pump Housing**

For the highest corrosion and sand-abrasion resistance

**Heavy-Duty Dual-Voltage Motor**

Preset at 115V



**1/2 HP 8 GPM**  
FP401215H

PERFORMANCE							MAX PRESSURE SHUTOFF	VOLTAGE	PRESS. SWITCH	
	0'	5'	10'	15'	20'	25'			ON	OFF
Depth to water	0'	5'	10'	15'	20'	25'	77 PSI	115/230	30	50
Gallons per minute	8	7.4	6.4	6.1	5.1	4.0				

All performances shown in gallons per minute at 40 PSI discharge pressure.

WARRANTY	UPC	CARTON DIMENSIONS	PALLET QTY.	WEIGHT
1 YEAR	022315101265	24.063" x 14.563" x 27.938"	5	48.75 LBS.

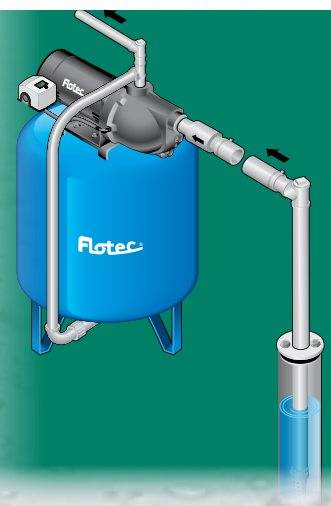

Includes:

Factory-installed 30/50 preset pressure switch, detailed owner's manual

# Cast Iron Shallow Well Jet Pumps

**With Built-in Pressure Switch**

## Rugged Cast Iron Construction

For heavy-duty applications

## Reliable Performance

At depths to water of 25' or less

## Ready-to-Install Motor

Operates at 115V

## Self-Priming After Pump Housing Is Initially Filled

Check valve or foot valve required, sold separately



**3/4 HP 8.3 GPM**  
FP4107

**1/2 HP 5.6 GPM**  
FP4105

PERFORMANCE (GPM)							MAX PRESSURE SHUTOFF	VOLTAGE	PRESSURE SWITCH	
DEPTH TO WATER	0'	5'	10'	15'	20'	25'			ON	OFF
<b>FP4107</b>	8.3	7.8	7.3	6.7	6.1	5.0	74 PSI	115	30	50
<b>FP4105</b>	5.6	5.1	4.5	4.1	3.5	3.1	63 PSI	115	30	50

All performances shown in gallons per minute at 40 PSI discharge pressure.

MODEL	WARRANTY	UPC	CARTON DIMENSIONS	PALLET QTY.	WEIGHT
<b>FP4107</b>	1 YEAR	022315322486	15.200" x 9.4" x 11"	27	23.55 LBS.
<b>FP4105</b>	1 YEAR	022315176225	15.200" x 9.4" x 11"	27	24.25 LBS.

Includes:

Factory-installed 30/50 preset pressure switch, detailed owner's manual

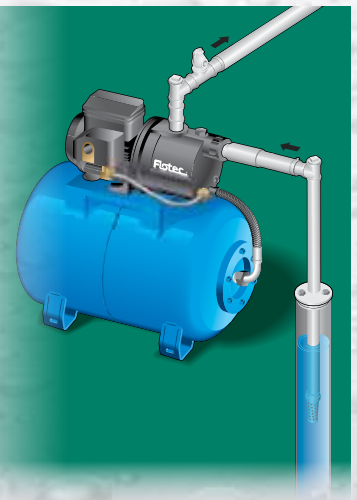

# Complete Jet & Tank System

**With Cast Iron Pump**

**Ideal for Compact Installations**

Where space is at a premium

**Reliable Performance**

At depths to water of 25' or less

**Precharged Pressure Tank with 15-Gallon Equivalent Capacity**

Corrosion-resistant, heavy-gauge steel construction with baked-on finish

**Durable Construction**

Heavy-duty cast iron pump housing

**Ready-to-Install Motor**

Operates at 115V



**1/2 HP** 5.6 GPM  
FP410515H

PERFORMANCE							MAX PRESSURE SHUTOFF	VOLTAGE	PRESSURE SWITCH	
									ON	OFF
Depth to water	0'	5'	10'	15'	20'	25'	63 PSI	115	30	50
Gallons per minute	5.6	5.1	4.5	4.1	3.5	3.1				

All performances shown in gallons per minute at 40 PSI discharge pressure.

WARRANTY	UPC	CARTON DIMENSIONS	PALLET QTY.	WEIGHT
1 YEAR	022315176232	20.5" x 23" x 12.25"	18	36.8 LBS.

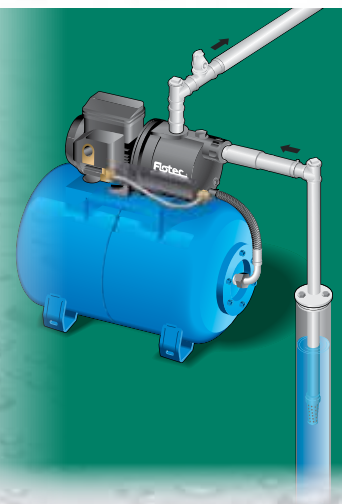

Includes:

Factory-installed 30/50 preset pressure switch, detailed owner's manual

# Cast Iron Shallow Well Jet Pumps

## High-Output Performance

### Rugged Pump Housing

Durable cast iron construction

### Superior Performance

At depths to water of 25' or less

### Built-in Prewired Pressure Switch

Set for 30/50 PSI operation

### Heavy-Duty Dual Voltage Motor

Preset at 230V



**1 HP** 21 GPM  
FP4150

**3/4 HP** 19 GPM  
FP4157

**1/2 HP** 8.5 GPM  
FP4155

PERFORMANCE (GPM)							MAX PRESSURE SHUTOFF	VOLTAGE	PRESSURE SWITCH	
DEPTH TO WATER	0'	5'	10'	15'	20'	25'			ON	OFF
<b>FP4150</b>	21.0	20.0	18.0	16.0	13.0	9.0	70 PSI	115/230	30	50
<b>FP4157</b>	19.0	16.0	14.0	13.0	11.0	7.0	67 PSI	115/230	30	50
<b>FP4155</b>	8.5	7.5	6.5	6.0	5.0	3.5	65 PSI	115/230	30	50

All performances shown in gallons per minute at 40 PSI discharge pressure.

MODEL	WARRANTY	UPC	CARTON DIMENSIONS	PALLET QTY.	WEIGHT
<b>FP4150</b>	1 YEAR	022315315150	19" x 10.82" x 10.5"	48	53 LBS.
<b>FP4157</b>	1 YEAR	022315100589	19" x 10.82" x 10.5"	48	45 LBS.
<b>FP4155</b>	1 YEAR	022315100572	19" x 10.82" x 10.5"	48	38 LBS.

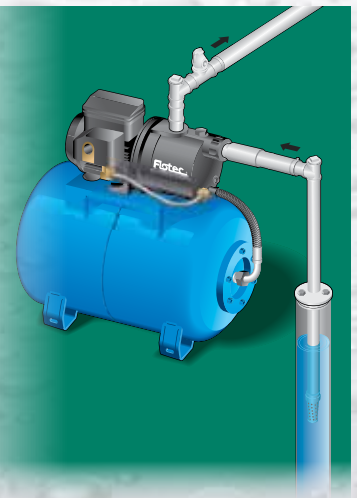

Includes:

Factory-installed 30/50 preset pressure switch, detailed owner's manual

# Complete Jet & Tank System

With High-Output Cast Iron Pump

### Superior Performance

At depths to water of 25' or less

### Compact System

Complete system with all necessary connectors from pump to tank

### Heavy-Duty Dual-Voltage Motor

Preset at 230V

### Durable Construction

Heavy-duty cast iron pump housing

### Precharged Pressure Tank with 15-Gallon Equivalent Capacity

Corrosion-resistant, heavy-gauge steel construction with baked-on finish



**1/2 HP** 8.5 GPM  
FP415515H

PERFORMANCE							MAX PRESSURE SHUTOFF	VOLTAGE	PRESSURE SWITCH	
	0'	5'	10'	15'	20'	25'			ON	OFF
Depth to water	0'	5'	10'	15'	20'	25'	65 PSI	115	30	50
Gallons per minute	8.5	7.5	6.5	6.0	5.0	3.5				

All performances shown in gallons per minute at 40 PSI discharge pressure.

WARRANTY	UPC	CARTON DIMENSIONS	PALLET QTY.	WEIGHT
1 YEAR	022315101265	23.25" x 14" x 26.88"	12	56 LBS.

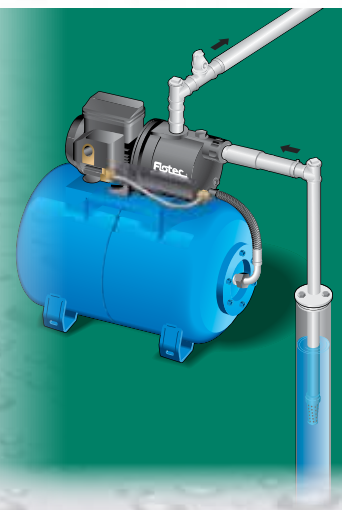

Includes:

Factory-installed 30/50 preset pressure switch, detailed owner's manual

# Cast Iron Shallow Well Jet Pumps

**With Built-in Pressure Switch**

## Rugged Pump Housing

Durable cast iron construction

## Superior Performance

At depths to water of 25' or less

## Heavy-Duty Dual-Voltage Motor

3/4 HP preset at 230V

1/2 HP preset at 115V

## Self-Priming After Pump Housing Is Initially Filled

Check valve or foot valve required, sold separately



**3/4 HP 14.7 GPM**  
FP4122

**1/2 HP 8.8 GPM**  
FP4112

PERFORMANCE (GPM)							MAX PRESSURE SHUTOFF	VOLTAGE	PRESSURE SWITCH	
DEPTH TO WATER	0'	5'	10'	15'	20'	25'			ON	OFF
<b>FP4122</b>	14.7	14.4	12.8	11.8	9.4	7.3	70 PSI	115/230	30	50
<b>FP4112</b>	8.8	8.5	7.8	6.8	5.6	4.6	69 PSI	115/230	30	50

All performances shown in gallons per minute at 40 PSI discharge pressure.

MODEL	WARRANTY	UPC	CARTON DIMENSIONS	PALLET QTY.	WEIGHT
<b>FP4122</b>	1 YEAR	022315100619	21.5" x 13.44" x 10.33"	24	43.3 LBS.
<b>FP4112</b>	1 YEAR	022315100602	21.5" x 13.44" x 10.33"	24	41 LBS.

Includes:

Factory-installed 30/50 preset pressure switch, detailed owner's manual

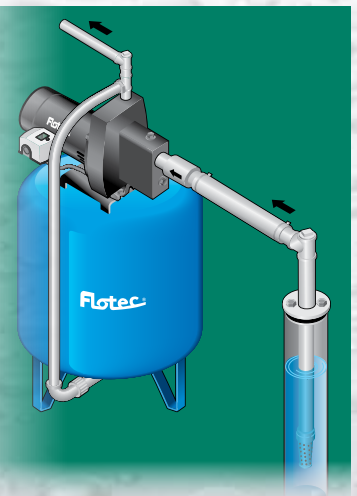

# Stainless Steel Shallow Well Jet Pumps

With Built-in Pressure Switch

## Heavy-Duty Stainless Steel Construction

For the highest corrosion-resistance

## Superior Performance

At depths to water of 25' or less

## Heavy-Duty Dual-Voltage Motor

Preset at 230V

## Self-Priming After Pump Housing Is Initially Filled

Check valve or foot valve required, sold separately



**1 HP 17.5 GPM**  
FP4832

**3/4 HP 11 GPM**  
FP4822

PERFORMANCE (GPM)							MAX PRESSURE SHUTOFF	VOLTAGE	PRESSURE SWITCH	
DEPTH TO WATER	0'	5'	10'	15'	20'	25'			ON	OFF
<b>FP4832</b>	17.5	16.2	14.6	12.6	10.6	7.5	81 PSI	115/230	30	50
<b>FP4822</b>	11.0	11.0	11.0	11.0	9.0	7.2	64 PSI	115/230	30	50

All performances shown in gallons per minute at 40 PSI discharge pressure.

MODEL	WARRANTY	UPC	CARTON DIMENSIONS	PALLET QTY.	WEIGHT
<b>FP4832</b>	1 YEAR	022315160613	21.313" x 11.313" x 12.625"	18	33.75 LBS.
<b>FP4822</b>	1 YEAR	022315160606	21.313" x 11.313" x 12.625"	18	29.05 LBS.

Includes:

Factory-installed 30/50 preset pressure switch, detailed owner's manual

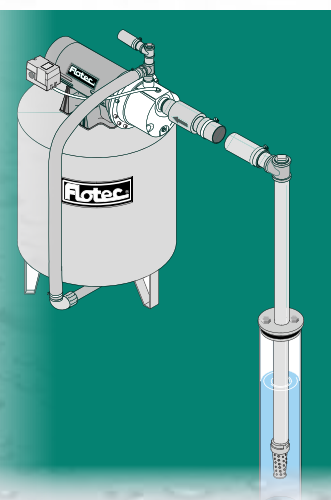

# Thermoplastic Convertible Jet Pumps

For Deep or Shallow Wells

## Superior Performance

At depths to water of 110' or less

## Fiberglass-Reinforced Thermoplastic Pump Housing

For the highest corrosion resistance

## Heavy-Duty Dual-Voltage Motor

3/4 HP & 1 HP preset at 230V  
1/2 HP preset at 115V

## Self-Priming After Pump Housing Is Initially Filled

Foot valve included with Jet Kit, sold separately

## Prewired Pressure Switch

Preset for 30/50 PSI operation

## Built-in Pressure Regulator

Includes:

Factory-installed 30 PSI gauge, preset pressure switch, detailed owner's manual



<b>1 HP</b>	<b>9 GPM</b>	<b>FP4332</b>	<b>3/4 HP</b>	<b>7.5 GPM</b>	<b>FP4322</b>	<b>1/2 HP</b>	<b>5.9 GPM</b>	<b>FP4312</b>
-------------	--------------	---------------	---------------	----------------	---------------	---------------	----------------	---------------

PERFORMANCE																							
MODEL/ UPC	HP	GPM	VOLTS	GALLONS PER MINUTE PUMPED AT DIFFERENT DEPTHS TO WATER IN FEET												PRESS. SHUTOFF AT MAX DEPTH	JET KIT	PRESS. SWITCH		CARTON DIMS. (INCHES)	WT. (LBS.)		
				5'	10'	15'	20'	30'	40'	50'	60'	70'	80'	90'	100'			110'	ON			OFF	
<b>FP4332</b> 022315100688	<b>1</b>	<b>9</b>	230/115															56 PSI	FP4800	30	50	20.94 x 12.31 x 12.19	30.35
				<b>Deep Well</b> with 4" dia. casing or larger																			
				<b>Deep Well</b> with 2" dia. casing																			
				<b>Shallow Well</b> of 25' or less				20.7	18.3	15.8	12.3	8.5	-	-	-	-	-						
<b>FP4322</b> 022315100671	<b>3/4</b>	<b>7.5</b>	230/115															56 PSI	FP4800	30	50	20.94 x 12.31 x 12.19	27.7
				<b>Deep Well</b> with 4" dia. casing or larger																			
				<b>Deep Well</b> with 2" dia. casing																			
				<b>Shallow Well</b> of 25' or less				15.3	13.8	11.8	9.2	6.8	-	-	-	-	-						
<b>FP4312</b> 022315100664	<b>1/2</b>	<b>5.9</b>	230/115															54 PSI	FP4800	30	50	20.94 x 12.31 x 12.19	54
				<b>Deep Well</b> with 4" dia. casing or larger																			
				<b>Deep Well</b> with 2" dia. casing																			
				<b>Shallow Well</b> of 25' or less				9.0	7.8	6.6	5.7	4.3											

All performances shown in gallons per minute at 40 PSI discharge pressure.



# Cast Iron Convertible Jet Pumps

For Deep or Shallow Wells

### Rugged Pump Housing

Durable cast iron construction

### Superior Performance

At depths to water of 100' or less  
(jet kit sold separately)

### Heavy-Duty Dual-Voltage Motor

3/4 HP preset at 230V  
1/2 HP preset at 115V

### Prewired Pressure Switch

Preset for 30/50 PSI operation

### Self-Priming After Pump Housing Is Initially Filled

Foot valve included with Jet Kit, sold separately

### Built-in Pressure Regulator



**3/4 HP** 7.5 GPM  
FP4222

**1/2 HP** 5.9 GPM  
FP4212

PERFORMANCE																						
MODEL/ UPC	HP	GPM	VOLTS													PRESS. SHUTOFF AT MAX DEPTH	JET KIT	PRESS. SWITCH		CARTON DIMS. (INCHES)	WEIGHT (LBS.)	
				5'	10'	15'	20'	30'	40'	50'	60'	70'	80'	90'	100'			ON	OFF			
<b>FP4222</b> 022315100640	<b>3/4</b>	<b>7.5</b>	230/115				7.5	6.5	5.1	4.0	3.0	2.5	1.8	1.5	1.0	56 PSI	FP4800	30	50	17.32 x 13.34 x 10.45	24	
				<b>Deep Well</b> with 4" dia. casing or larger																		
				<b>Deep Well</b> with 2" dia. casing				6.8	6.2	4.8	3.7	2.6	2.1	1.5	1.2	0.8	53 PSI	FP4840			48/PALLET	
				<b>Shallow Well</b> with single pipe				11.9	10.8	9.5	7.5	-	-	-	-	-	-	-	63 PSI	FP4855		
<b>FP4212</b> 022315100633	<b>1/2</b>	<b>5.9</b>	230/115				5.9	4.5	3.5	2.8	2.3	1.7	-	-	-	54 PSI	FP4800	30	50	17.32 x 13.34 x 10.45	21	
				<b>Deep Well</b> with 4" dia. casing or larger																		
				<b>Deep Well</b> with 2" dia. casing				5.3	4.3	3.0	2.5	1.9	1.5	1.1	-	-	54 PSI	FP4840			48/PALLET	
				<b>Shallow Well</b> with single pipe				7.9	7.1	6.3	5.4	-	-	-	-	-	-	-	60 PSI	FP4855		

All performances shown in gallons per minute at 40 PSI discharge pressure.

Includes: Factory-installed 30/50 preset pressure switch, detailed owner's manual

# Cast Iron Convertible Jet Pumps

For Deep or Shallow Wells

## Rugged Pump Housing

Durable cast iron construction

## Superior Performance

At depths to water of 70' or less

## Heavy-Duty Dual-Voltage Motor

3/4 HP preset at 230V  
1 HP preset at 230V  
1/2 HP preset at 115V

## Replaceable Pressure Switch

Preset for 30/50 PSI operation

## Self-Priming After Pump Housing Is Initially Filled

Check valve or foot valve required, sold separately

Includes:

Pressure regulator, pressure gauge & detailed owner's manual



## Ejector Kit Included for 4" Wells or Larger

**1 HP** 10 GPM  
FP4210

**3/4 HP** 8 GPM  
FP4207

**1/2 HP** 5 GPM  
FP4205

PERFORMANCE																		
MODEL/ UPC	HP	GPM	VOLTS	GALLONS PER MINUTE PUMPED AT DIFFERENT DEPTHS TO WATER IN FEET										PRESS. SHUTOFF AT MAX DEPTH	PRESS. SWITCH		CARTON DIMS. (IN INCHES)	WEIGHT (LBS.)
				0'	5'	10'	15'	20'	30'	40'	50'	60'	70'		ON	OFF		
<b>FP4210</b> 022315100640	<b>1</b>	<b>10</b>	230/115	-	-	-	-	-	10.0	8.0	6.0	4.5	3.5	65 PSI	30	50	17.32 x13.34 x 10.45 48/PALLET	24
<b>Deep Well</b> with 4" diameter casing or larger																		
<b>Shallow Well</b> of 25' or less				17.0	15.0	13.5	12.5	10.0	-	-	-	-	-	70 PSI				
<b>FP4207</b> 022315100633	<b>3/4</b>	<b>8</b>	230/115	-	-	-	-	-	8.0	6.0	4.5	3.5	2.5	65 PSI	30	50	17.32 x13.34 x 10.45 48/PALLET	21
<b>Deep Well</b> with 4" diameter casing or larger																		
<b>Shallow Well</b> of 25' or less				16.0	14.5	13.5	12.0	10.0	-	-	-	-	-	70 PSI				
<b>FP4205</b> 022315100633	<b>1/2</b>	<b>5</b>	230/115	-	-	-	-	-	5.0	4.0	3.0	2.5	2.0	65 PSI	30	50	17.32 x13.34 x 10.45 48/PALLET	21
<b>Deep Well</b> with 4" diameter casing or larger																		
<b>Shallow Well</b> of 25' or less				10.0	9.5	9.0	8.0	6.5	-	-	-	-	-	54 PSI				

All performances shown in gallons per minute at 40 PSI discharge pressure. Pipe size required: 1-1/4" suction, 1" drive, 1" discharge

# Complete Jet & Tank System

For Deep or Shallow Wells

## Superior Performance

At depths to water of 70' or less

## Compact System

Complete system with pressure gauge, pressure switch, pressure regulator, jet kit and all necessary connectors from pump to tank

## Heavy-Duty Dual-Voltage Motor

Preset at 115V

## Durable Construction

Heavy-duty cast iron pump housing

## Precharged Pressure Tank with 15-Gallon Equivalent Capacity

Corrosion-resistant, heavy-gauge steel construction with baked-on finish



**1/2 HP** 5 GPM  
FP420515H

### PERFORMANCE

MODEL/ UPC	HP	GPM	VOLTS	GALLONS PER MINUTE PUMPED AT DIFFERENT DEPTHS TO WATER IN FEET										PRESS. SHUTOFF AT MAX DEPTH	PRESS. SWITCH		CARTON DIMS. (IN INCHES)	WEIGHT (LBS.)
				0'	5'	10'	15'	20'	30'	40'	50'	60'	70'		ON	OFF		
<b>FP420515H</b> 022315361713	<b>1/2</b>	<b>8.5</b>	230/115	-	-	-	-	-	5.0	4.0	3.0	2.5	2.0	77 PSI	30	50	23.25 x14 x 26.88	56
<b>Deep Well</b> with 4" diameter casing or larger																		
<b>Shallow Well</b> of 25' or less				10	9.5	9	8	6.5	-	-	-	-	-	54 PSI				

Includes:

Factory-installed 30/50 preset pressure switch, detailed owner's manual

# Cast Iron Jet Pump

## Vertical Deep Well

### Rugged Housing

Durable cast iron construction

### Superior Performance

At depths to water of 260'

### High Capacity

Up to 12 gallons per minute at 50 PSI

### Heavy-Duty Dual-Voltage Motor

Preset at 230V

### Prewired Factory-Set 40/60 Pressure Switch

### Jet Kit Sold Separately



**1 HP** 12 GPM  
FP4432

PERFORMANCE	GALLONS PER MINUTE PUMPED AT DIFFERENT DEPTHS TO WATER IN FEET																
	30'	40'	50'	60'	70'	80'	90'	100'	110'	120'	130'	140'	180'	200'	220'	240'	260'
Deep Well with 4" diameter casing or larger (FP4800)	12.0	11.5	11.0	10.4	9.6	8.8	7.4	6.1	5.0	4.9	4.7	4.5	2.9	2.3	1.7	1.2	0.8
Deep Well with 2" diameter casing (FP4840)	12.0	11.2	10.7	9.4	8.3	7.3	6.3	5.0	5.0	4.9	4.3	4.2	1.8	-	-	-	-

\*All performances shown in gallons per minute at 40 PSI discharge pressure.  
Pipe size required: 1-1/4" suction, 1" drive, 1" discharge

WARRANTY	UPC	CARTON DIMENSIONS	PALLET QTY.	WEIGHT
1 YEAR	022315200791	11.88" x 15.38" x 26.63"	18	73.2 LBS.

Includes:

Factory-installed 40/60 preset pressure switch, pressure gauge, mounting feet, detailed owner's manual

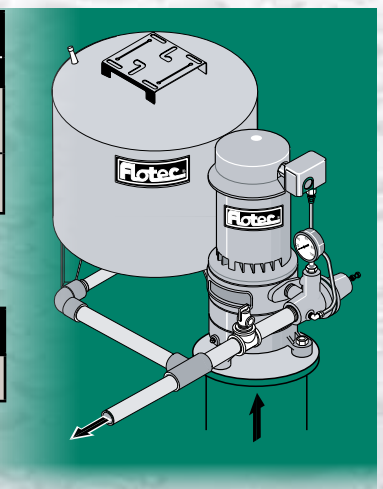

# Cast Iron • Multi-Stage High Pressure Booster Pumps

## Typical Application

When you need to boost your existing pressure by 50 to 130 PSI. Residential, commercial or agricultural high pressure washing.

## Stainless Steel Motor Shaft

Includes heavy-duty ball bearings, on-board thermal overload protection and rated for continuous duty

## Heavy-Duty Cast Iron Pump Adapter and Discharge

3/4" suction and discharge



**1 HP** 190 PSI  
FP5732

**3/4 HP** 150 PSI  
FP5722

**1/2 HP** 110 PSI  
FP5712

PERFORMANCE												
MODEL/UPC	HP	MAX. PSI	VOLTS	GALLONS PER MINUTE					NPT PIPE SIZE		CARTON DIMS. (IN INCHES)	WT. (LBS.)
				50	70	90	110	130	SUCTION	DISCH.		
<b>FP5732</b> 022315165779	<b>1</b>	<b>190</b>	230/115	-	-	13	12	10.5	3/4"	3/4"	30.063 x 9.188 x 12.563 18/PALLET	48
<b>FP5722</b> 022315165762	<b>3/4</b>	<b>150</b>	230/115	-	13	10	8	-	3/4"	3/4"	30.063 x 9.188 x 12.563 18/PALLET	42.9
<b>FP5712</b> 022315165755	<b>1/2</b>	<b>110</b>	230/115	13	11	7	-	-	3/4"	3/4"	30.063 x 9.188 x 12.563 18/PALLET	38.9

Includes:

Detailed owner's manual

# 3-Wire, 4" Submersible Well Pumps

## For Residential Water Systems or Agricultural Applications

Pumps to depth of 400'

### High Performance

Proven floating stack impeller design for sand resistance and reduced sand locking

### Durable Construction

Stainless steel pump and motor housing



**Control Box Included**

**1/2 HP – 1 HP** 14-26.2 GPM

PERFORMANCE																
MODEL/ UPC	HP	GPM	VOLTS	GALLONS PER MINUTE PUMPED AT DIFFERENT DEPTHS TO WATER IN FEET											CARTON DIMS. (IN INCHES)	WEIGHT (LBS.)
				20'	40'	60'	80'	100'	150'	200'	250'	300'	350'	400'		
<b>FP3332</b> 022315101975	<b>1</b>	<b>26.2</b>	230	26.2	-	26.2	24.3	22.3	17.3	8	-	-	-	-	5 x 4.5 x 43.5	46
<b>FP3242</b> 022315100916	<b>1-1/2</b>	<b>16</b>	230	-	-	-	-	14.9	13.8	12.5	11.2	9.7	7.9	5.8	6 x 4.5 x 49	41
<b>FP3232</b> 022315101968	<b>1</b>	<b>15.6</b>	230	-	-	14.7	14	13.4	11.7	9.7	7.3	4.4	-	-	6 x 4.63 x 40	39
<b>FP3222</b> 022315101951	<b>3/4</b>	<b>15</b>	230	14.8	14.2	13.4	12.6	11.7	8.8	5.2	-	-	-	-	6 x 4.63 x 40	35
<b>FP3212</b> 022315101944	<b>1/2</b>	<b>14</b>	230	13.2	12.2	10.9	9.6	8.1	2	-	-	-	-	-	21 x 12.5 x 12.25	34

\*All performances shown in gallons per minute at 40 PSI discharge pressure at the top of the well.

Includes:

Control box & detailed owner's manual

# 2-Wire, 4" Submersible Well Pumps

## For Residential Water Systems or Agricultural Applications

Pumps to depth of 300'

### High Performance

Proven floating stack impeller design for sand resistance and reduced sand locking

### Durable Construction

Stainless steel pump and motor housing



**1/2 HP – 1 HP** 10-14 GPM

PERFORMANCE																
MODEL/ UPC	HP	GPM	VOLTS	GALLONS PER MINUTE PUMPED AT DIFFERENT DEPTHS TO WATER IN FEET											CARTON DIMS. (IN INCHES)	WEIGHT (LBS.)
				20'	40'	60'	80'	100'	150'	200'	250'	300'	350'	400'		
<b>FP2232</b> 022315100824	<b>1</b>	<b>15.6</b>	230	-	-	14.7	14	13.4	11.7	9.7	7.3	4.4	-	-	4.63 x 5 x 29	37
<b>FP2222</b> 022315100817	<b>3/4</b>	<b>14.9</b>	230	14.8	14.2	13.4	12.6	11.7	8.8	5.2	-	-	-	-	4 x 4.75 x 34.25	32
<b>FP2212</b> 022315100800	<b>1/2</b>	<b>13.6</b>	230	13.2	12.2	10.9	9.6	8.1	2	-	-	-	-	-	4.75 x 4.75 x 33	29
<b>FP2211</b> 022315155787	<b>1/2</b>	<b>13.6</b>	115	13.2	12.2	10.9	9.6	8.1	2	-	-	-	-	-	4.75 x 4.75 x 34	29

\*All performances shown in gallons per minute at 40 PSI discharge pressure at the top of the well.

Includes:

Detailed owner's manual

# 2 & 5 Gallon Precharged Pressure Tanks

## Vertical Design

### Factory Precharged to 20 PSI for Efficiency

Extends pump life by providing more water between pump cycles compared to standard tanks

### Heavy-Gauge Steel Construction

For maximum durability and extended life

### Precision Press Fit Design

Minimizes gaps between components, reducing corrosion and seam leaks

### Convenient Size

Ideal for small water systems and lower-flow applications

### Easy Maintenance

NSF-61-approved tank is non-replaceable diaphragm



**5 GAL** FP7107

**2 GAL** FP105

PERFORMANCE										
MODEL	STANDARD TANK EQUIVALENCY	ACTUAL TANK CAPACITY	DRAWDOWN COMPARISON						STYLE	PLUMBING CONNECTION
			PRECHARGED			STANDARD				
			20/40	30/50	40/60	20/40	30/50	40/60		
FP7107	13 Gallons	5 Gallons	1.8	1.5	1.3	1.7	1.5	1.3	Vertical	3/4"
FP7105	6 Gallons	2 Gallons	0.7	0.6	0.5	0.9	0.6	-	Vertical	3/4"

MODEL	WARRANTY	UPC	CARTON DIMENSIONS	PALLET QTY.	WEIGHT
FP7107	5 YEAR	022315363687	13" x 8" x 8"	N/A	6.4 LBS.
FP7105	5 YEAR	022315101449	8.6" x 9" x 13.6"	162	5 LBS.

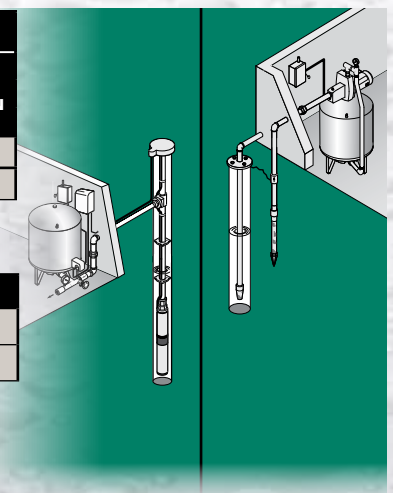

Includes:

Detailed owner's manual



# 6 Gallon Precharged Pressure Tanks

## Vertical or Horizontal Design

### Factory Precharged to 40 PSI for Efficiency

Extends pump life by providing more water between pump cycles compared to standard tanks

### Heavy-Gauge Steel Construction

For maximum durability and extended life

### Precision Press Fit Design

Minimizes gaps between components, reducing corrosion and seam leaks

### Convenient Size

Ideal for cabins and summer homes

### Easy Maintenance

NSF-61-approved tank replaceable air/water separator



**6 GAL** FP7100

**6 GAL** FP7100H (Horizontal)

## PERFORMANCE

MODEL	STANDARD TANK EQUIVALENCY	ACTUAL TANK CAPACITY	DRAWDOWN COMPARISON						STYLE	PLUMBING CONNECTION
			PRECHARGED			STANDARD				
			20/40	30/50	40/60	20/40	30/50	40/60		
<b>FP7100</b>	15 Gallons	6 Gallons	2.2	1.8	1.8	2.3	1.5	1.1	Vertical	3/4"
<b>FP7100H</b>	15 Gallons	6 Gallons	2.2	1.8	1.8	2.3	1.5	1.1	Horizontal	3/4"

MODEL	WARRANTY	UPC	CARTON DIMENSIONS	PALLET QTY.	WEIGHT
<b>FP7100</b>	5 YEAR	022315101098	14.063" x 12.813" x 17.313"	18	18.9 LBS.
<b>FP7100H</b>	5 YEAR	022315101081	14.063" x 12.813" x 17.313"	18	18 LBS.

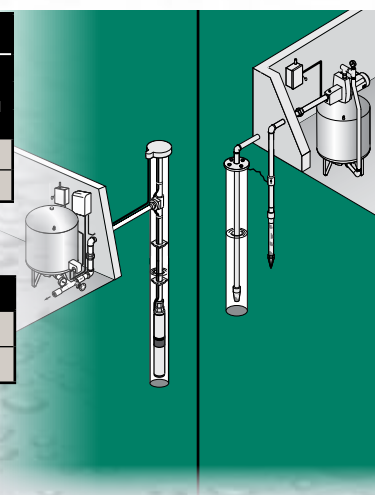

Includes:

Detailed owner's manual

# 19 Gallon Precharged Pressure Tanks

Vertical or Horizontal Design

## Factory Precharged to 40 PSI for Efficiency

Extends pump life by providing more water between pump cycles compared to standard tanks

## Heavy-Gauge Steel Construction

For maximum durability and extended life

## Precision Press Fit Design

Minimizes gaps between components, reducing corrosion and seam leaks

## Convenient Size

Ideal for household applications

## Easy Maintenance

NSF-61-approved tank  
Replaceable air/water separator



**19 GAL** FP7110T

**19 GAL** FP7110TH

**19 GAL** FP7110

PERFORMANCE										
MODEL	STANDARD TANK EQUIVALENCY	ACTUAL TANK CAPACITY	DRAWDOWN COMPARISON						STYLE	PLUMBING CONNECTION
			PRECHARGED			STANDARD				
			20/40	30/50	40/60	20/40	30/50	40/60		
FP7110T	42 Gallons	19 Gallons	6.9	5.9	5.0	6.5	4.3	3.0	Vertical	1"
FP7110TH	42 Gallons	19 Gallons	6.9	5.9	5.0	6.5	4.3	3.0	Horizontal	1"
FP7110	42 Gallons	19 Gallons	6.9	5.9	5.0	6.5	4.3	3.0	Vertical	1"

MODEL	WARRANTY	UPC	CARTON DIMENSIONS	PALLET QTY.	WEIGHT
FP7110T	5 YEAR	022315101203	16.75" x 16.75" x 29.313"	4	36.5 LBS.
FP7110TH	5 YEAR	022315101388	18.31" x 16.813" x 27.313"	6	38.5 LBS.
FP7110	5 YEAR	022315101098	14.063" x 12.813" x 17.313"	18	18.9 LBS.

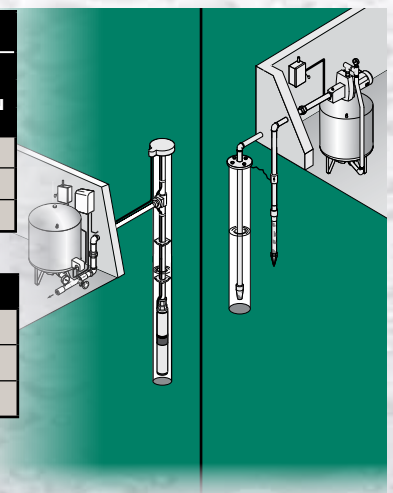

Includes:

Detailed owner's manual

# 35, 50, 85 & 119 Gallon Precharged Pressure Tanks

## Vertical Design

### Factory Precharged to 40 PSI for Efficiency

Extends pump life by providing more water between pump cycles compared to standard tanks

### Heavy-Gauge Steel Construction

For maximum durability and extended life

### Precision Press Fit Design

Minimizes gaps between components, reducing corrosion and seam leaks

### Large Capacity

Ideal for high demand water usage

### Easy Maintenance

NSF-61-approved tank  
Replaceable air/water separator



**119 GAL** FP7135

**85 GAL** FP7130

**50 GAL** FP7125

**35 GAL** FP7120

PERFORMANCE										
MODEL	STANDARD TANK EQUIVALENCY	ACTUAL TANK CAPACITY	DRAWDOWN COMPARISON						STYLE	PLUMBING CONNECTION
			PRECHARGED			STANDARD				
			20/40	30/50	40/60	20/40	30/50	40/60		
FP7135	320 Gallons	119 Gallons	41.3	35.4	31.0	47.0	29.0	24.4	Vertical	1-1/4"
FP7130	220 Gallons	85 Gallons	30.0	26.0	22.0	34.1	22.4	16.1	Vertical	1-1/4"
FP7125	120 Gallons	50 Gallons	18.3	15.5	13.4	18.6	12.2	8.8	Vertical	1-1/4"
FP7120	82 Gallons	35 Gallons	12.7	10.7	9.3	12.7	8.4	5.9	Vertical	1"

MODEL	WARRANTY	UPC	CARTON DIMENSIONS	PALLET QTY.	WEIGHT
FP7135	5 YEAR	022315173675	24.813" x 24.813" x 69.818"	2	153 LBS.
FP7130	5 YEAR	022315101135	24.563" x 24.563" x 56.063"	2	117.7 LBS.
FP7125	5 YEAR	022315101128	24.563" x 24.563" x 33.188"	2	82.35 LBS.
FP7120	5 YEAR	022315101111	20.813" x 20.813" x 34.313"	4	61.6 LBS.

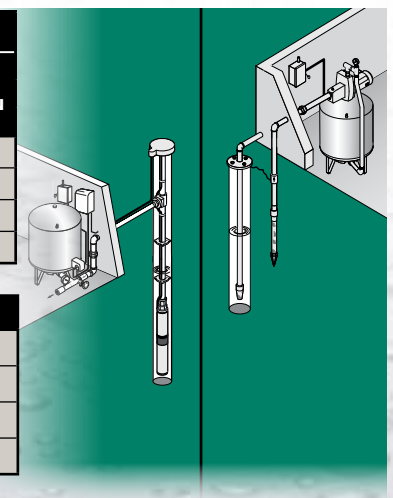

Includes:

Detailed owner's manual

# Epoxy-Lined Standard Tanks

Vertical or Horizontal Design

## Typical Applications

Replaces any standard galvanized, glass-lined or epoxy-lined tank for applications such as retention tanks, holding tanks and pressure tanks

## Precision Press Fit Design

Minimizes gaps between components, reducing corrosion and seam leaks

## Heavy-Gauge All-Steel Construction

Tough appliance-like finish for extended life



**42 GAL** FP7235

**30 GAL** FP7230  
FP7210 (Horizontal)

MODEL	TANK SIZE	STYLE	DIAMETER	HEIGHT	LENGTH	PIPING SIZE
FP7235	42 gallons	Vertical	20"	36"	N/A	1-1/4"
FP7210	30 gallons	Horizontal	16"	17-1/2"	36-1/2"	3/4"
FP7230	30 gallons	Vertical	16"	53-1/2"	N/A	1-1/4"

MODEL	WARRANTY	UPC	CARTON DIMENSIONS	PALLET QTY.	WEIGHT
FP7235	1 YEAR	022315135901	20.813" x 20.813" x 37.938"	4	58 LBS.
FP7210	1 YEAR	022315364783	37.813" x 16.313" x 17.938"	6	51 LBS.
FP7230	1 YEAR	022315101234	16.813" x 16.813" x 54.813"	6	56.3 LBS.

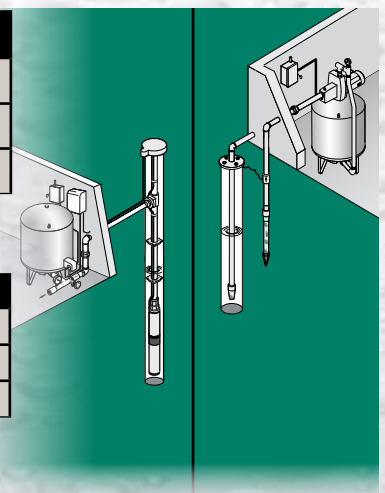

Includes:

Detailed owner's manual

# Epoxy-Lined Standard Tanks

## Vertical Design

### Typical Applications

Replaces any standard galvanized, glass-lined or epoxy-lined tank for applications such as retention tanks, holding tanks and pressure tanks

### Precision Press Fit Design

Minimizes gaps between components, reducing corrosion and seam leaks

### Heavy-Gauge All-Steel Construction

Tough appliance-like finish for extended life



**120 GAL** FP7250

**85 GAL** FP7240

MODEL	TANK SIZE	STYLE	DIAMETER	HEIGHT	LENGTH	PIPING SIZE
<b>FP7250</b>	120 gallons	Vertical	24"	68"	N/A	1-1/4"
<b>FP7240</b>	85 gallons	Vertical	24"	51"	N/A	1-1/4"

MODEL	WARRANTY	UPC	CARTON DIMENSIONS	PALLET QTY.	WEIGHT
<b>FP7250</b>	1 YEAR	022315162938	24.813" x 24.813" x 69.818"	2	142 LBS.
<b>FP7240</b>	1 YEAR	022315135918	24.813" x 24.813" x 51.563"	2	109.35 LBS.

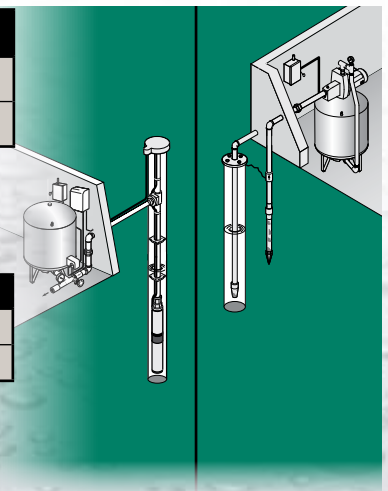

Includes:

Detailed owner's manual

# Jet Pump Accessories

## Pressure Switches

20/40 PSI	FP2040
30/50 PSI	TC2151
30/50 PSI with Low-Pressure Cutoff	FP217-1140
40/60 PSI	TC2153
Pressure Relief Valve	TC2160LF
Pressure Regulator Valve Kit	FPAPR
Pressure Switch Tubing Kit	FPASFK
Pressure Gauge	TC2104
Air Volume Control Kit	TC2120
Tank Hook-up Kit	FP8110



## Jet Pump Overhaul Kits

<b>Convertible &amp; Shallow Well Jet Kit</b> For use with FP4112 and FP4212	FPP1560
<b>Convertible &amp; Shallow Well Jet Kit</b> For use with FP4122 and FP4222	FPP1561
<b>Convertible Jet Kit</b> For use with FP4312	FPP1511
<b>Shallow Well</b> For use with FP4012-08	FPP1520
<b>Shallow Well</b> For use with FP4012-08	FPP1521



## Seal and Gasket Kits

<b>Shallow Well Jet</b> For use with FP4000 (-08)	FPP1530
<b>Convertible and Shallow Well Jet</b> For use with FP4112, FP4122, FP4222	FPP1550
<b>Shallow Well</b> For use with FP4300	FP4875
<b>4" Double Pipe Deep Well</b> For use with FP4200, FP4300, FP4400	FP4800
<b>2" Single Pipe Deep Well</b> For use with FP4200, FP4300, FP4400	FP4840



# Submersible Pump Accessories

## Pitless Adapters

1"	A10148LF
1-1/4"	A10113LF
Torque Arrestor	FP97-33
Wire Guard	TC2171LF
Air Volume Control Kit	FPE238-2
Wire Splice Kit	TC2172



## Wiring Kits

For 2-Wire Pumps, 1 HP and Under	FP85
For 3-Wire Pumps, 2 HP and Under	FP86
Installation Wiring Kit for 3-Wire Pumps, 2 HP and Under	FP87

Includes 150' 12-gauge 3-wire plus ground, brass tank tee, pressure switch, pressure gauge, torque arrestor and wire splice kit



# Submersible Pump Accessories (cont.)

## Brass Check Valves

3/4"	TC2506LF
1"	TC2502LF
1-1/4"	TC2505LF
1-1/2"	TC2507LF
2"	FPU212-36LF



## Brass Foot Valves

3/4"	TC2508LF
1"	TC2503LF
1-1/4"	TC2501LF
1-1/2"	TC2504



## Brass Barb Fittings

1" x 1"	FPU78-993LF
1-1/4" x 1"	FPU78-992LF



## Discharge Tees

1"	FPADT
1-1/2"	FPADT-15



## Brass Tank Tees

4"	TCU78-635DLF
1 1/2"	FP78-7LF





# Well Accessories

## Well Seals

4" x 1-1/4" drop pipe sizes	FP216-13
4" x 1-1/4" x 1" drop pipe sizes	FP216-92
6" x 1" drop pipe sizes	FP216-6
6" x 1-1/4" x 1" drop pipe sizes	FP216-94
Well Cap	FPU216-111



## Well Drive Points

1-1/4" x 36"	J208-2
1-1/4" x 48"	J48-12
Well Point Drive Coupling	J11-6
Well Point Drive Cap	J70-1
Pitcher Pump	FPHP25
Tank Fill Pump-up Float Switch	FPW217-180B



J11-6



J70-1



FPW217-180B

FPHP25

## Hydrants

1' bury depth	FPH1
2' bury depth	FPH2
3' bury depth	FPH3
4' bury depth	FPH4
5' bury depth	FPH5
6' bury depth	FPH6
8' bury depth	FPH8
Hydrant Installation Kit	FPHK
Hydrant Repair Kit	FPYRK1



FPHK



FPYRK1

## Limited Warranty

This Limited Warranty is effective June 1, 2011 and replaces all undated warranties and warranties dated before June 1, 2011.

FLOTEC warrants to the original consumer purchaser ("Purchaser" or "You") that its products are free from defects in material and workmanship for a period of twelve (12) months from the date of the original consumer purchase. If, within twelve (12) months from the original consumer purchase, any such product shall prove to be defective, it shall be repaired or replaced at FLOTEC's option, subject to the terms and conditions set forth herein. Note that this limited warranty applies to manufacturing defects only and not to ordinary wear and tear. All mechanical devices need periodic parts and service to perform well. This limited warranty does not cover repair when normal use has exhausted the life of a part or the equipment.

The original purchase receipt and product warranty information label are required to determine warranty eligibility. Eligibility is based on purchase date of original product – not the date of replacement under warranty. The warranty is limited to repair or replacement of original purchased product only, not replacement product (i.e. one warranty replacement allowed per purchase). Purchaser pays all removal, installation, labor, shipping, and incidental charges.

For parts or troubleshooting assistance, DO NOT return product to your retail store - contact FLOTEC Customer Service at 1-800-365-6832. Claims made under this warranty shall be made by returning the product (except sewage pumps, see below) to the retail outlet where it was purchased or to the factory immediately after the discovery of any alleged defect. FLOTEC will subsequently take corrective action as promptly as reasonably possible. No requests for service will be accepted if received more than 30 days after the warranty expires. Warranty is not transferable and does not apply to products used in commercial/rental applications.

### Sewage Pumps

DO NOT return a sewage pump (that has been installed) to your retail store. Contact FLOTEC Customer Service. Sewage pumps that have seen service and been removed carry a contamination hazard with them.

If your sewage pump has failed:

- Wear rubber gloves when handling the pump;
- For warranty purposes, return the pump's cord tag and original receipt of purchase to the retail store;
- Dispose of the pump according to local disposal ordinances.

### Exceptions to the Twelve (12) Month Limited Warranty

Product	Warranty Period
FPOF360AC, FPOFDC	90 days
FPOS1775A, FPOS1790PCA, FPOS2400A, FPOS2450A, FPOS4100X, FP2800DCC, FPCP-20ULST, FPPSS3000, FPSC2150A, FPSC3150A, FPSC3350A	2 Years
4" Submersible Well Pumps, FPOS3200A, FPOS3250A, FPOS6000A, FPSC1725X, FPSC2200A, FPSC2250A, FPSE3601A, FPPSS5000	3 Years
FP7100 Series Pressure Tanks, E100ELT, E3305TLT, E3375TLT, E5005TLT, E50TLT, E50VLT, E75STVT, E75VLT, FPSC3200A, FPSC3250A, FPSC4550A	5 Years

### General Terms and Conditions

You must pay all labor and shipping charges necessary to replace product covered by this warranty. This warranty does not apply to the following: (1) acts of God; (2) products which, in FLOTEC's sole judgment, have been subject to negligence, abuse, accident, misapplication, tampering, or alteration; (3) failures due to improper installation, operation, maintenance or storage; (4) atypical or unapproved application, use or service; (5) failures caused by corrosion, rust or other foreign materials in the system, or operation at pressures in excess of recommended maximums.

This warranty sets forth FLOTEC's sole obligation and purchaser's exclusive remedy for defective products.

FLOTEC SHALL NOT BE LIABLE FOR ANY CONSEQUENTIAL, INCIDENTAL, OR CONTINGENT DAMAGES WHATSOEVER.

THE FOREGOING LIMITED WARRANTIES ARE EXCLUSIVE AND IN LIEU OF ALL OTHER EXPRESS AND IMPLIED WARRANTIES, INCLUDING BUT NOT LIMITED TO IMPLIED WARRANTIES OF MERCHANTABILITY AND FITNESS FOR A PARTICULAR PURPOSE. THE FOREGOING LIMITED WARRANTIES SHALL NOT EXTEND BEYOND THE DURATION PROVIDED HEREIN.

Some states do not allow the exclusion or limitation of incidental or consequential damages or limitations on how long an implied warranty lasts, so the above limitations or exclusions may not apply to You. This warranty gives You specific legal rights and You may also have other rights which vary from state to state.

**Air Volume Control** – Designed to maintain the air charge in a standard water storage tank. Precharged tanks do not use an air volume control.

**Atmospheric Pressure** – A force exerted upon the Earth's surface by the weight of air extending to a height of 25 miles above the earth. At sea level, 14.7 pounds per square inch (PSI).

**Black Water** – Raw human sewage.

**Centrifugal Force** – The force created by a spinning or rotating impeller resulting in the movement of water outward from the center point. A pump uses an impeller to create centrifugal force.

**Check Valve** – Allows water to move in only one direction, which prevents water from returning to its source.

**Convertible Jet Pump** – For deep wells where pumping water levels are as far as 90 feet below the pump. Also easily converted for shallow wells where pumping water levels are no more than 25 feet below the pump. Jet packages must be purchased separately.

**Cut-in Pressure Setting** – The point at which the pressure switch turns the pump on.

**Deep Well** – Well with a depth to water greater than 25 feet.

**Depth to Water** – The vertical measurement from pump level down to the top of the water in your well.

**Discharge Pressure** – The amount of force or pressure of the water being discharged from the pump.

**Dual-Voltage Motor** – Pump motor that can be operated on 115 or 230 volt service by simply changing the internal motor leads located under the motor canopy to correspond with the power supply.

**Effluent** – Sewage or wastewater which has undergone some pre-treatment. Effluent water may contain small solids and/or stringy material (lint, hair, etc.). Effluent is generally defined as 3/4" solids or less.

**Foot Valve** – Installs on end of pump suction pipe to prevent water from draining back to source. Includes strainer to minimize suction of debris into pump.

**GPH** – Gallons per hour.

**GPM** – Gallons per minute.

**Gray Water** – Non-toilet household wastewater (sinks, showers, laundry, etc.) that is sometimes recycled, especially for use in gardening or for flushing toilets.

**Head** – A term used to define water pressure in vertical feet. Or a term representing the energy content of a liquid, expressed as the height of an equivalent vertical column of water. a. This is expressed in feet of head. b. This can apply to both sides of a pump: the suction side and discharge side. c. It is also used to express the total losses in a pumping system (Total Dynamic Head).

**HP** – Horsepower (size rating of motor).

**Jet Package** – Required for operation of convertible and deep well jet pumps.

**Jet Pump** – A centrifugal pump which requires a jet, either built-in or purchased separately, to help build additional water pressure.

**Lift** – Lift is essentially the distance water has to travel between your sump basin and the highest vertical point in the drainage pipe. The most common lift height is 10 feet.

**Precharged Tank** – A water storage tank precharged with air at factory featuring a vinyl bag to separate water from air which prevents waterlogging. This tank design provides greater drawdown than standard tanks. Precharged tanks do not require an air volume control. (See Water Storage Tank, Waterlogging, Tank Drawdown.)

**Pressure** – A force usually expressed in pounds per square inch (PSI).

**Pressure Relief Valve** – Required for all submersible pump and pressure boosting installations to prevent overpressurization of water storage tank and system piping that could develop from pressure switch malfunction.

**Pressure Switch** – The switch that automatically turns the pump on and off at specified pressures 30/50 PSI and 40/60 PSI. IMPORTANT! Always replace an old switch with a new switch with the same pressure settings.

**30/50 pressure operation** – Pressure switch turns pump on at 30 PSI, off at 50 PSI.

**40/60 pressure operation** – Pressure switch turns pump on at 40 PSI, off at 60 PSI.

**Priming the Pump** – The initial filling of a jet or centrifugal pump with water so that the air can be removed.

**Pump Capacity** – The amount of water a pump is capable of moving at a given pressure.

**PSI** – Pounds per square inch. A unit of water and air pressure measurement.

**Self-Priming Pump** – A centrifugal pump having the capability of dispersing a certain amount of air from its pump body, assuming the pump has been primed initially, when operating under a suction lift; to free itself of entrained gas without losing prime; and to continue normal pumping operation without attention.

**Sewage** – Raw wastewater from residential, commercial or industrial sites. Sewage from residential sites is generally defined as 2" solids.

**Shallow Well** – Well with a depth to water of 25 feet or less.

**Sizing** – Properly matching pump to application for best performance.

**Standard Tank** – A pressurized water storage tank where air comes in contact with water. Requires air volume control for proper operation.

**Submersible Control Box** – Installs aboveground. Contains electrical starting components for 3-wire submersible deep well pumps. 2-wire submersible deep well pumps do not use a control box.

**Submersible Deep Well Pump** – For use on wells where pump water levels are up to 400 feet below point of use. Pump is submerged underwater in well.

**Suction Lift** – See Depth to Water.

**Sump Pump** – An electric pump that is placed in the basement of a home and is used to remove water from the basement to outside the home.

**Tank Drawdown/Drawdown** – The amount of usable water available from a water storage tank between pump stops and starts.

**Waterlogging** – The absorption of air into water stored in a water storage tank, which greatly reduces the amount of usable water drawdown available from the tank.

**Water Storage Tank** – Stores air and water under pressure to provide for automatic pump operation and a source of water when pump is not running.

**Well Diameter** – Inside dimension of well casing.



For more than 30 years, Flotec® has been a leader in providing water system products to solve residential water management needs. Flotec offers a wide range of products from utility pumps to complete water systems. All Flotec products are designed for easy installation and are backed by industry-leading warranties.



[www.flotecwater.com](http://www.flotecwater.com)

293 Wright Street, Delavan, WI 53115

1-800-365-6832 fax: 1-800-526-3757

